

OMS, a.s.

Dojč 419
906 02 Dojč, Slovakia
info@oms.sk
Tel.: +421 34 694 0811
Fax: +421 34 694 0888

www.omslighting.com

Oms® RIGHTLIGHTOFFICE

RIGHTLIGHTOFFICE

Oms®



OMS, a.s.

Dojč 419
906 02 Dojč, Slovakia
info@oms.sk
Tel.: +421 34 694 0811
Fax: +421 34 694 0888

www.omslighting.com

The need to create a space for working together has its roots already in ancient Greece. In atriums with a circular plane the statesmen discussed and decided about crucial issues. The invention of book printing in 1450 changed the demands on the official rooms. Gathering documents required completing the desks with some closable furniture, bookshelves as well as shelf systems. Until the end of the 17th century the office became not only a purpose-built place for work, but also a fully-fledged representative space which differed affluent and important citizens from common clerks and copyists.

The office space as we know it today began to form at the beginning of the 20th century, substantially affected by the functionalist style Bauhaus. In the course of time it was "melt down" into a space defined by minimalism. Especially the generation of "white collars" and the gradual implementation of new technologies brought principal changes in the conception of the office space. The closed office spaces gradually begin to retreat in favour of the "open space" with isolated systems of partially closed cells. The new arrangement of the office space also brings changes of the demands for the illumination. The static solution is replaced by dynamic lighting, the modern luminaires and intelligent "light management systems" optimise the energy intensity of the space.

The offices more than any time in the past resemble a space with a complex infrastructure. It becomes an inspiring space which is to stimulate higher performance efficiency, but at the same time to offer the possibility to have a rest. In this context, the light plays a key role: it stimulates higher performance efficiency, supports the ability to concentrate, it increases the feeling of comfort of the individual. The proper lighting of the office space, beginning with the desk up to the open space office exceeds the boundaries of the technical standards; it fulfils the aesthetic and ergonomic functions in a still greater extent and respects the individual needs of every workplace. The lighting quality is one of the key parameters when solving the architecture of the office space. The company SLE responds to this fact by its own system of assessing the quality of the lighting system – the Lighting Quality Standard.

CONTENT

LIGHT AND US	8	LIGHT IN THE OFFICE	56
ERGONOMICS	10	RECEPTION AND FOYER	60
COLOUR RENDERING INDEX (CRI)	12	OPEN SPACE OFFICE	64
GLARE PREVENTION	14	CELLULAR OFFICE	68
ILLUMINATION LEVEL	16	HEAD OFFICE	72
LIGHTING UNIFORMITY	18	MEETING AND CONFERENCE ROOM	74
HARMONIOUS DISTRIBUTION OF BRIGHTNESS	20	RELAXING ZONES	80
EMOTION	24	COMMUNICATIONS AND CORRIDORS	84
BIOLOGICAL FACTOR OF ILLUMINATION	26	EMERGENCY AND SAFETY LIGHTING	86
AVAILABILITY OF DAYLIGHT	26	FACADE	92
BLUELIGHT CONTENT	26	PARKING AREAS	96
DAYLIGHT SIMULATION	28		
ILLUMINATION OF ROOM SURFACES	30	SELECTION OF THE RIGHT LIGHT SOURCE	98
EMOTIONAL LIGHTING	32	LED FOR OFFICE	110
ECOLOGY	34	PRODUCTS	106
LATEST LAMP TECHNOLOGY	36		
SYSTEM EFFICACY OF LUMINAIRE	38		
THERMAL OUTPUT OF LAMP	39		
DANGEROUS MATERIAL CONTENT	40		
PRODUCT LIFE-TIME AND MAINTENANCE	40		
EFFICIENCY	42		
DAYLIGHT SENSOR	44		
CONSTANT ILLUMINANCE SENSOR	45		
PRESENCE DETECTOR	46		
CALLING OF LIGHTING SCENES	48		
ESPRIT	50		
EXCEPTIONALITY	52		



LIGHTING AND US

BRINGING ORDER TO THE LIGHTING WORLD

When designing the lighting system of the office space the lighting designer has to take into account, besides the legal standards, also other parameters which are no less important and affect the quality of the lighting solution of the whole office building. Until recently, the summary of these criteria has represented a chaotic system that has not offered any sufficient overview to the customer. The six-point assessment system of the lighting quality – Lighting Quality Standard developed by the company SLE brings a new order to the chaotic lighting world.

Living by rules is important.

Respecting laws is relevant as well. The ancient conflict of our world is driven by patterns and order; otherwise we become adrift by chaos that is present in our civilisation to these days. Whether the former or the latter concept is the right one, is an eternal question. One thing is certain: we in SLE love the order much more than chaos. That is why we have created a brand new lighting quality standard to help the customers, buyers and competitors better understand and evaluate lighting devices and solutions.

Until now there was no unifying system used in the world of lighting for evaluation of either light fixtures or lighting solutions, and every producer has got its own way for that. Consumers get lost in the vast array of criteria used and comparing neither products nor solution was an option. SLE brings order to this chaos. We are prepared to help the LQS become a unified standard used by the whole lighting sector. No overstatement, the LQS is an important step to a new level. Not just for our company, but for the branch and the giant world of lighting.

We have chosen more than twenty objectively quantifiable criteria and we are using them to evaluate both individual light fixtures and complete lighting solutions for different types of spaces. Each criterion has got its value and the result is the LQS Index. The higher the index is, the better the lighting device or solution is for use in a given space. Simple and intuitive approach to the agenda is exemplified by the LQS Composer, a unique tool to evaluate each and every lighting product.

There is a six-part program behind the acronym LQS. The chapters are named **ERGONOMICS, EMOTION, ECOLOGY, EFFICIENCY, ESPRIT AND EXCEPTIONALITY** or just **6 E's**. If you imagine a house, the first four chapters are strong pillars representing criteria that are well-known in the world of lighting. The remaining two are the roof, a powerful superstructure on the top of these pillars. Together, they create an inseparable complex, because the parts of the whole cannot be perceived independently, but only in their context. That is the basic philosophy of the LQS. Immerse in the 6 E's and conceive the idea of living in a place where rules are crystal clear.

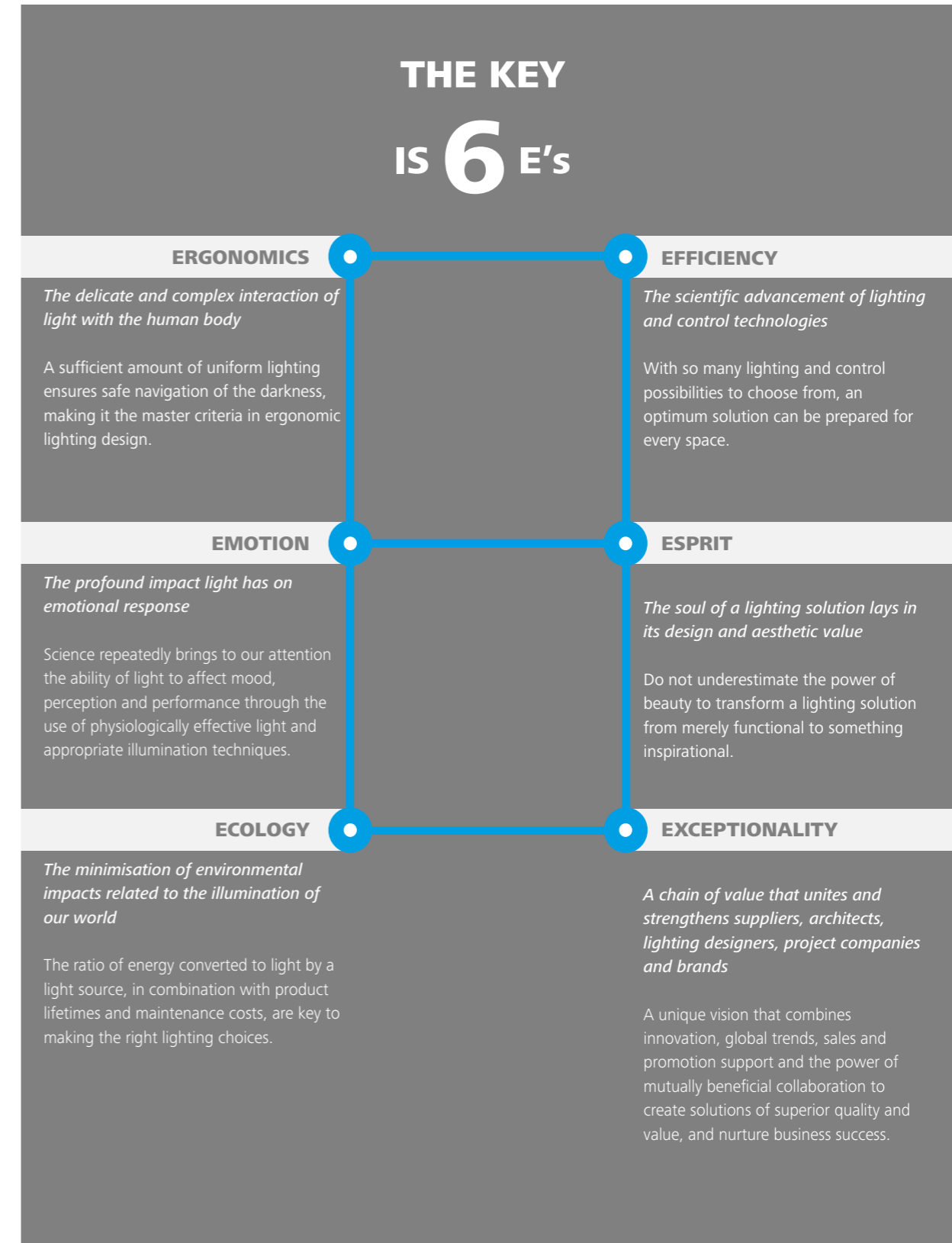

ERGONOMICS

The modern people spend more than half of their productive life at work. Therefore, respecting the ergonomic standards at workplaces (when designing the lighting system) is the most important premise. By adequate lighting we are able to reduce the undesirable glare, to improve performance efficiency and ability to concentrate, to prevent sight damage as well as stressful and dangerous situations.

The appropriate ergonomics of lighting at the workplace enables the easier identification of objects and items in the space. The knowledge of principles during designing an office building enables the developer and architect to make the correct choice.

Nowadays nowhere else respecting the ergonomic standards appears as important as at the workplace where the modern people spend more than half of their productive life. The appropriate lighting of this place is able to reduce the undesirable glare, to improve the performance efficiency and ability to concentrate, to prevent sight damage as well as stressful and dangerous situations.

The basic quantities which are taken into account by the ergonomics when creating optimal lighting conditions are – the Colour Rendering Index (CRI), glare prevention, illumination level, illumination of the task area and surrounding task area, lighting uniformity and harmonious distribution of brightness.

A suspended luminaire with both direct and indirect distribution represents an ideal technological solution for office space illumination.

A modern office resembles a place with a complex infrastructure. It becomes a space of inspiration.



One of the key tasks of the designer is to create such light conditions which will ensure the correct perception of colours.

COLOUR RENDERING INDEX

The light and colours define the atmosphere in the room and therefore, ensuring the correct perception of colours is one of the key designer's roles when solving the illumination.

The influence of the artificial light source on the appearance of the colour objects is expressed by the colour rendering index (CRI) which indicates how truthfully the individual light sources are able to copy the object's colouring compared with daylight. The CRI value of the luminaire is expressed by the average of the first eight factors R1 – R8 out of fifteen colour samples illuminated at first under a reference light source with an ideal value (CRI = 100) and under the light source being tested. The larger the difference of the truthfulness of colour reproduction is, the lower the CRI value of the tested light source is and thus, also its ability to display the object's colouring truthfully.

From the practical point of view, the colour rendering index is one of the most important aspects when selecting the light source. The European standard EN 12 464-1 requires light sources with the colour rendering index of minimally 80 for a common office to use, lower values are admitted only for living spaces, corridors and warehouses. From the point of view of LQS the highest ranking is assigned to the light sources with CRI 90 and more.



Concept "Brilliant Mix"

The system Brilliant mix was developed by SLE in collaboration with Osram Opto semiconductor (Regensburg, Germany) and Mazet (Jena, Germany). The Brilliant mix is a demonstration of what white light of high quality SLE is able to produce.

The principle of Brilliant mix is based on mixing three LED colours ("blue" white, "green" EQ-WHITE and "red" amber) in one luminaire and the result is a white colour with a high colour rendering index. By adding/taking away individual channels it is simultaneously possible to change the correlated colour temperature of the white light in a wide range (2700 – 4000 K). It is important that every adjusted colour temperature has a durably high CRI of more than 90 and a relatively high efficacy (lm/W). The whole concept is completed with electronics which are able to control each channel independently and a colour sensor which permanently evaluates the CRI and CCT data. If the values differ from those being selected, the sensor gives the electronic a command for correction. In this way permanent monitoring of the light quality during the whole LED life cycle is ensured.

Using the concept Brilliant mix we can achieve that all luminaires installed in one room have the exact same CCT value permanently.



Comparison of colour rendering indexes – CRI. Left: CRI 70. Right: CRI 93



In the architects' offices, rooms determined for technical drawing and in CAD rooms the correct colour rendering is of exceptional importance therefore, usage of light sources with colour rendering index 90 is recommended.

LQS VALUE

Colour rendering index (CRI)

CRI	LQS Value
>90	5
80-90	4
70-80	3
60-70	2
40-60	1
20-40	0

GLARE PREVENTION

Glare is a negative visual perception aroused by light surfaces in the field of vision. Preventing it or minimising its occurrence is particularly important not only from the point of view of the visual comfort but also the safety. The excessive direct and reflected glare at the workplace cause fatigue, visual impairment, it can lead to reduced concentration, it makes the text visibility on the PC monitor as well as reading a printed text on the glossy paper more difficult. Preventing the disruptive glare belongs therefore to the basic designer's tasks when planning a light solution.

In the office spaces the glare is especially undesirable in the spaces where visual display units are placed. The excessive light can decrease the contrast of the image on the visual display units by veiling reflections caused by dazzling of the screen surface, the luminance of the luminaires and bright surfaces which are reflected on the screen. The requirements on the visual quality of the screens concerning the undesirable reflections are stated by the European standard ISO 9241-307.

Reducing the risk of exposing the employees to the glare begins with the correct organisation of the workplace. Placing the desks rectangular to the glass window areas for the daylight not to reflect directly to the eye and to fit them out with the blinds are the basic measures of the glare prevention.

LQS VALUE

Glare prevention

Glare prevention	LQS Value
URG<16	5
URG<19	4
URG<22	3
URG<25	2
URG<28	1
URG>28	0



A suspended LED luminaire with direct and indirect distribution of diffuse light through microprism is an ideal solution for the office spaces.

Unified Glare Rating

The method of Unified Glare Rating (UGR) is used for uniform qualification of the rate of the psychological glare. This method was defined by the Commission Internationale de l'Eclairage.

$$UGR = 8 \log \left[\frac{0.25}{L_b} \sum \frac{L^2 \Omega}{p^2} \right]$$

Where L stands for luminance of lighting parts of every luminaire in the direction of the eye (in candelas per square meter). Ω is a cut-off angle of a luminaire relative to the eye of an observer (in sr). P is a Guth factor of spatial position of every single luminaire relative to the field of view. Finally, L expresses background illuminance (in candelas per square meter).

The European standard EN 12464-1 states the UGR maximally 16 for workplaces with high demands on precision and a high rate of visual load (technical drawing), for common workplaces (registration of documents, CAD workstations, conference halls and meeting rooms) UGR 19, for receptions UGR 22 and for archives 25.

LQS assigns the highest rating of 5 points to solutions achieving UGR maximally 16 and less.

Microprism

A suspended LED luminaire with direct and indirect distribution of diffuse light through microprism is an ideal solution for the office spaces. The microprism represents the most effective method for the diffuse light distribution as the light breaks at the end of the material, on the so called optical prisms which results in its uniform distribution. The soft diffuse light is more pleasant for the human eye, it strains less and in this way the rate of psychological load UGR is reduced.

Another way how to prevent glare is a correct selection of the lighting fixture and its appropriate placement in the space. It is recommended to choose luminaires with low luminance and mat surface and to place them in such a way that the ray of light will not reflect from the objects directly to the eye, e.g. when sitting at the desk while carrying out everyday activities.

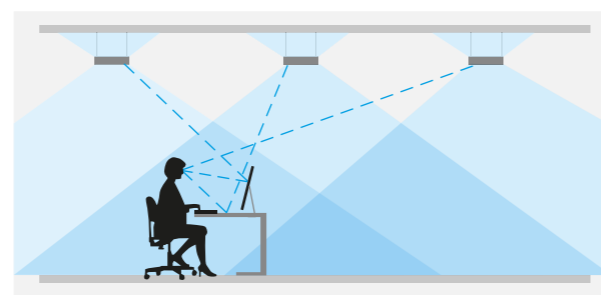

The correct illumination of the task area creates optimal conditions for employees to work. You will prevent their feeling of fatigue, reduction of concentration and you will also prevent situations in which they could make unnecessary failures

Screen high state luminance	High luminance screen L > 200 cd/m ²	Medium luminance screen L ≤ 200 cd/m ²
Case A Values for spaces with common demands on the correct colour rendering and details of the depicted information that is relevant e.g. for all types of offices.	≤ 3000 cd/m ²	≤ 1500 cd/m ²
Case B Values for spaces with increased demands on the colour rendering, precise work and details of the depicted information, e.g. technical drawing, CAD workstations, etc.	≤ 1500 cd/m ²	≤ 1000 cd/m ²

The limit values of the lighting fixtures' luminance in the angle of 65° and more from the vertical axis.

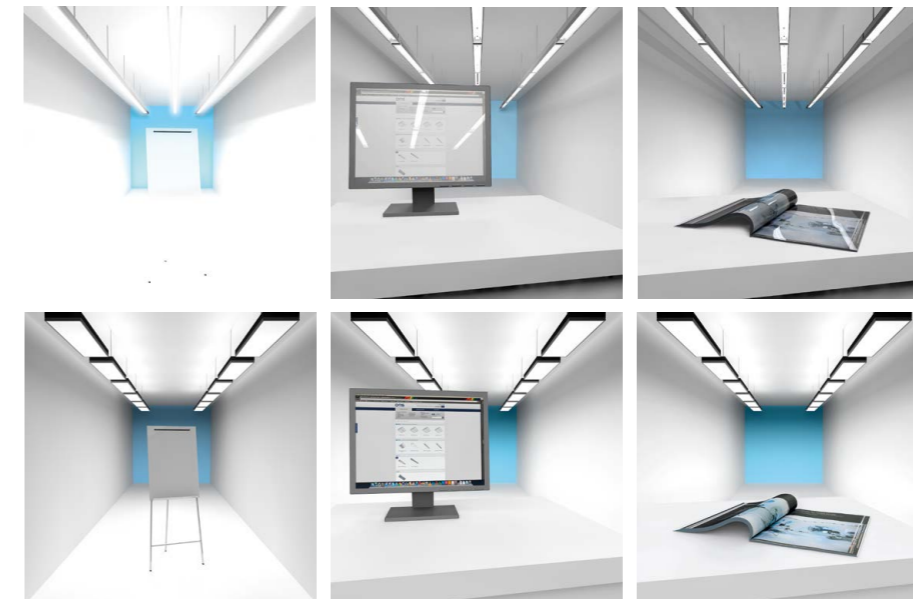

Direct glare causes excessive luminance, e.g. from incorrectly placed luminaires or from unshielded general-diffuse lamps. It arouses a feeling of psychological as well as visual discomfort and therefore it is inevitable to reduce it to minimum.

Reflected glare represents the same psychological and physiological load as the direct glare and moreover it reduces the capability to perceive contrasts. It is aroused by a disruptive reflection of light falling from unshielded windows from the glossy surfaces e.g. glossy paper or monitor).

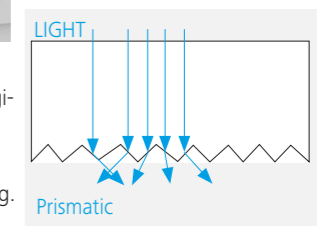

Excessive glare causes fatigue, visual impairment; it can lead to reduced concentration and make the text visibility on the PC monitor more difficult.

Correct illumination of the space enables correct perception of visual information, recognising objects and faces.

ILLUMINATION LEVEL **Task Area**

The light substantially affects the feeling of people's comfort; it influences their psyche, performance, ability to concentrate and regeneration. The correct illumination of the space makes it possible to perceive the visual information, recognising the object shapes and faces correctly. In general the optimal solution is considered when the luminaire in the office spaces is placed towards the working surface slightly from the left of the employee's view. When the situation is solved like this the employees do not cast a shadow upon the desk when they are writing and also good visibility of the pen's nib is ensured. Such a direction of the luminous flux is determined for the right-handers; the left-handers are often disadvantaged in this case. However, currently there are lighting solutions which enable adjusting the luminous flux to create the same conditions also for the left-handers.

From the point of view of demands on the illumination of the office space, it is the desk or the task area that plays the most important role. The European standard EN 12464-1 states the value of minimally 500 lx for the common administrative activities and tightens the requirements on the illumination level to the value of 750 lx for those task areas where time-demanding tasks, tasks requiring precision, productivity, concentration are carried out or where the visual capability of the employee is reduced.

The appropriate organisation of the task area can prevent damaging the people's sense

of sight and support the employees' concentration at the workplace. If the task area includes the PC monitor and a paper document the optimal distance of the space for the monitor and document is 40 to 80 centimetres for them

to be approximately in the same distance from the eye. Larger differences of distance place heavier demands on the adaptation capability of the human eye and bring feelings of fatigue.

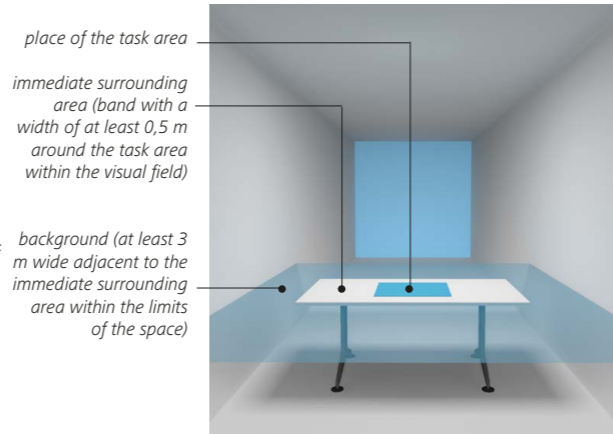

Surrounding Area

The correct illumination of surrounding area (band with a width of at least 0.5 m around the task area within the visual field) and the background (at least 3 m wide adjacent to the immediate surrounding area within the limits of the space) is an important factor in the office space. Their correct illumina-

tion can prevent problems with perceiving the objects, it can minimise the damage of the sense of sight, developing stress and strain.

The illuminance of the surrounding area and the background is connected with the illuminance of the task area and is to ensure a balanced lumi-

nance distribution in the field of vision. The standard EN 12464-1 states for the surrounding area a 65 – 75 % rate of the task area illumination, for the background area the boundary is minimally one third of the surrounding area value.

LQS assigns the spaces meeting requirements of the standard 5 points; those failing to fulfil the illumination value level 0 points.

It is beneficial to use a free-standing luminaire with direct-indirect flux as a supplementary lighting fixture to illuminate the task area and help achieve constant lighting conditions. The direct flux is determined for lighting the working area and

Illuminance on the task area E_{task} lx	Illuminance on immediate surrounding areas lx
≥ 750	500
500	300
300	200
200	150
150	E_{task}
100	E_{task}
≤ 50	E_{task}



LQS VALUE

Illumination level (task area)

Illumination level (task area)	LQS Value
Yes	5
No	0

LQS VALUE

Illumination level (surrounding area)

Illumination level (surrounding area)	LQS Value
Yes	5
No	0

The uniform illumination affects our ability to perceive the surrounding area and to orient ourselves inside of it.

A uniformly illuminated space is perceived as a consistent one. Big differences in the rate of illumination create the impression of a broken space and tire the sight.

LIGHTING UNIFORMITY

The uniform illumination affects our ability to perceive the surrounding area and to orient ourselves inside of it. We perceive a uniformly illuminated space a consistent one, on the contrary, big differences in the illumination rate create the impression of a broken space and increase demands on the adaptation capability of the human eye. The lighting uniformity can be expressed as a ratio of the minimal and average illuminance of the space assessed. The closer their values are, the more uniform the illuminance of the space is.

An optimal state can be achieved by selecting an appropriate type and number of luminaires and their correct distribution. From the point of view of type of luminaires the direct and indirect lighting fixtures with a wide luminous intensity curve seem to be the most suitable.

The lighting uniformity index is adapted by the European standard 12464-1 which, as in the case of the illumination level, places heavier demands on workplaces requiring precision (e.g. technical drawing). For these ones it states the index with a minimal value of 0.7.

From the point of view of LQS, the optimal lighting solution meeting the standard is assessed by 5 points, those failing to fulfil requirements by 0 points.

LQS VALUE

Lighting uniformity

Lighting uniformity	LQS Value
Yes	5
No	0

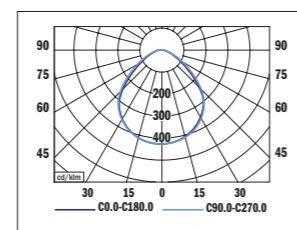
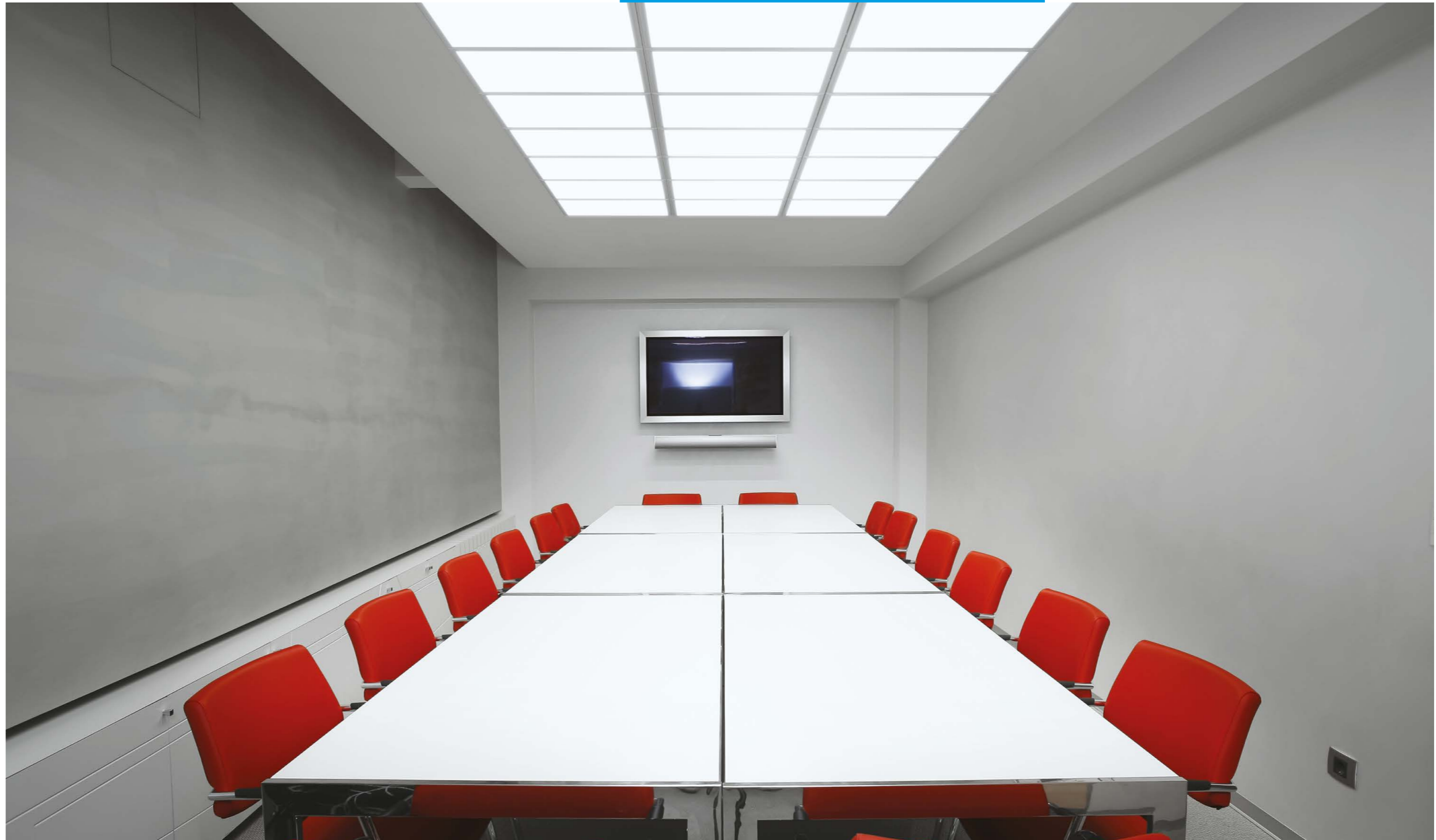

Luminous intensity curve

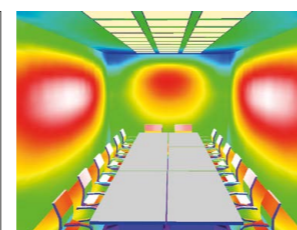

A specialised software dialux enables a simulation of the lighting uniformity of the space already during the design phase of the lighting system.

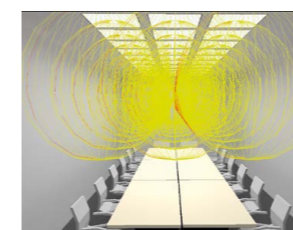

Already the luminous intensity curve gives the designer a hint about the resulting effect.

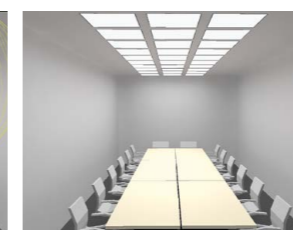

The customer acquires the visualisation of the room space including the definitions of the material surfaces and parts of the interior as well.

An outstanding lighting uniformity in the offices that have to fulfil demanding requirements of the standard can be achieved by placing a lighting fixture with a cosine luminous intensity curve. These requirements can be fulfilled by a recessed ceiling luminaire with a direct characteristic of the luminous flux distribution.

Brightness is the only quantity the human eye responds to. Its uniform distribution in the office space has key importance for a correct visual perception.

Harmonious distribution of brightness affects sharpness of vision and enables the human eye to perceive contrast. The low contrast reduces the visual stimulation, causes eye fatigue and in this way it affects the performance efficiency negatively.

HARMONIOUS DISTRIBUTION OF BRIGHTNESS

People acquire up to 80 % of information through their sense of vision therefore lighting is the key factor for a correct visual perception. Brightness is the only quantity to which the human eye responds and therefore its distribution is the key factor when planning the illumination in every type of space including the office buildings. Harmonious distribution of brightness affects sharpness of vision and enables the human eye to perceive the contrast. Unequal distribution of brightness places increased demands on the adaptation ability of the human eye, the low contrast reduces the visual stimulation, causes eye fatigue and in this way it affects the performance efficiency at the workplace. Excessive brightness in the space causes an undesirable glare.

To achieve an optimal distribution of brightness in the space means to begin with a correct organisation of the interior and its design. The types of the material and colour used are decisive. In general, it is recommended to use brighter colours because dark walls, ceilings as well as furniture have, in comparison to the brighter materials, a lower reflectance and therefore they can cause depressive feelings. An appropriate selection of the luminaire (ceiling or suspension



lighting fixtures with direct/indirect distribution of the luminous flux) and their correct deployment are a key factor for the harmonious distribution of brightness.

The standards for harmonious distribution of brightness are defined by the norm EN 12464-1 which recommends the value of the reflection factor of the main interior surfaces 0.7 to 0.9; for the walls 0.5 to 0.8 and for the floor 0.2 to 0.4. For the value of the reflection factor of large objects (e.g. furniture) it states the range of 0.2 to 0.7. The standard EN 12464-1 also determines the values for maintained illuminance of the main surfaces in the office spaces. For the illuminance of the walls it determines minimally 50 lx (for offices up to 75 lx) with the uniformity of ≥ 0.10 , for ceilings 30 lx (for offices up to 50 lx) with the uniformity of ≥ 0.10 . Lower values in an office building are allowed only in the warehouses.

The optimal illumination of the workplace fulfilling the requirements of the standards on harmonious distribution of brightness can also be achieved nowadays by installing the recessed luminaires that are able to reflect sufficient amounts of light to the ceiling.

LQS VALUE

Harmonious distribution of brightness

Harmonious distribution of brightness (contrast)	LQS Value
Em(wall)>150lx with U ₀ >0.3 Em(ceiling)>75lx with U ₀ >0.3	5
Em(wall)>75lx with U ₀ >0.3 Em(ceiling)>50lx with U ₀ >0.3	4
Em(wall)>75lx with U ₀ >0.1 Em(ceiling)>50lx with U ₀ >0.1	3
Em(wall)>50lx with U ₀ >0.1 Em(ceiling)>30lx with U ₀ >0.1	2
Em(wall)>30lx with U ₀ >0.1 Em(ceiling)>10lx with U ₀ >0.1	1
Em(wall)<30lx with U ₀ >0.1 Em(ceiling)<10lx with U ₀ >0.1	0



Luminaires with direct characteristic of the luminous flow distribution are insufficient for the harmonious distribution of brightness in the office.

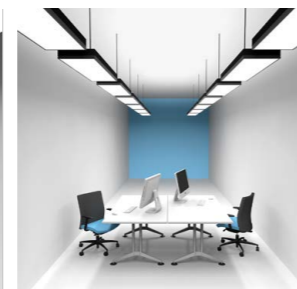

Optimal values for distribution of brightness in the space can be achieved by using suspension luminaires with both direct and indirect characteristics of the luminous flux distribution.

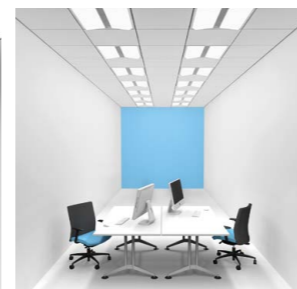

A similar result as with the suspension luminaires with direct and indirect characteristics of the luminous flux distribution can be achieved with recessed luminaires with a specially shaped diffuser.

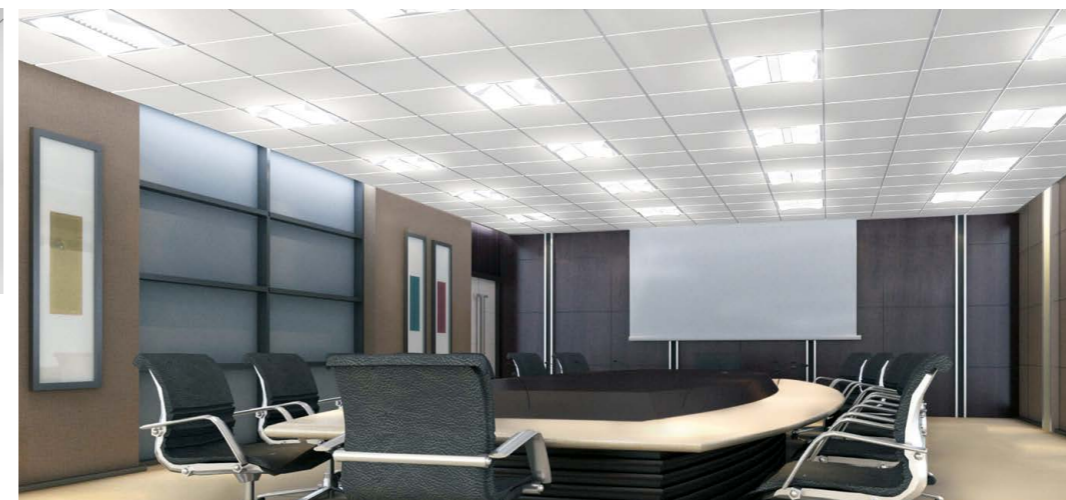

To achieve an optimal distribution of brightness in the space means to begin with a correct organisation of the interior and its design. The types of the material and colour used are decisive.

MINIMUM LIGHTING REQUIREMENTS RECOMMENDED BY EN 12464

Type of area, task or activity	Em [lx]	UGR	U0	CRI	Specific requirements
Offices					
Filing, copying, etc.	300	19	0.4	80	
Writing, typing, reading, data processing	500	19	0.6	80	VDU work (see Glare prevention)
Technical drawing	750	16	0.7	80	
CAD work stations	500	19	0.6	80	VDU work (see Glare prevention)
Conference and meeting rooms	500	19	0.6	80	Lighting should be controllable.
Reception desk	300	22	0.6	80	
Archives	200	25	0.4	80	
Public areas					
Entrance halls	100	22	0.4	80	UGR only if applicable.
Cloakrooms	200	25	0.4	80	
Waiting rooms	200	22	0.4	80	
Reception/cashier desk, porters desk	300	22	0.6	80	
Traffic zones inside buildings					
Circulation areas and corridors	100	28	0.4	40	<ol style="list-style-type: none"> 1. Illuminance at floor level. 2. Ra and UGR similar to adjacent areas. 3. 150 lx if there are vehicles on the route. 4. The lighting of exits and entrances shall provide a transition zone to avoid sudden changes in illuminance between inside and outside by day or night. 5. Care should be taken to avoid glare to drivers and pedestrians.
Stairs, escalators, travelators	100	25	0.4	40	Requires enhanced contrast on the steps.
Elevators, lifts	100	25	0.4	40	Light level in front of the lift should be at least $\bar{E}_m = 200$ lx.
Loading ramps/bays	150	25	0.4	40	
Other rooms					
Canteens	200	22	0.4	80	
Kitchen	500	22	0.6	80	
Break rooms	100	22	0.4	80	
Rooms for physical exercise	300	22	0.4	80	
Cloakrooms, washrooms, bathrooms, toilets	200	25	0.4	80	In each individual toilet if these are fully enclosed.
Sick bay	500	19	0.6	80	
Rooms for medical attention	500	16	0.6	90	4.000 K <TCP < 5.000 K
Plant rooms, switch gear rooms	200	25	0.4	60	
Mail rooms, telephone switch places	500	19	0.6	80	
Store and stockrooms	100	25	0.4	60	200 lx if continuously occupied.
Dispatch packing handling areas	300	25	0.6	60	
Places of public assembly - Public car parks					
Traffic lanes	75	25	0.4	40	<ol style="list-style-type: none"> 1. Illuminances at floor level. 2. Safety colours shall be recognisable.
Parking areas	75	-	0.4	40	<ol style="list-style-type: none"> 1. Illuminances at floor level. 2. Safety colours shall be recognisable. 3. A high vertical illuminance increases recognition of peoples faces and therefore the feeling of safety.
In/out ramps (at night)	75	25	0.4	40	<ol style="list-style-type: none"> 1. Illuminances at floor level. 2. Safety colours shall be recognisable.
In/out ramps (during the day)	300	25	0.4	40	<ol style="list-style-type: none"> 1. Illuminances at floor level. 2. Safety colours shall be recognisable.
Ticket office	300	19	0.6	80	<ol style="list-style-type: none"> 1. Reflections in the windows shall be avoided. 2. Glare from outside shall be prevented.

MINIMUM LIGHTING REQUIREMENTS RECOMMENDED BY EN 12464

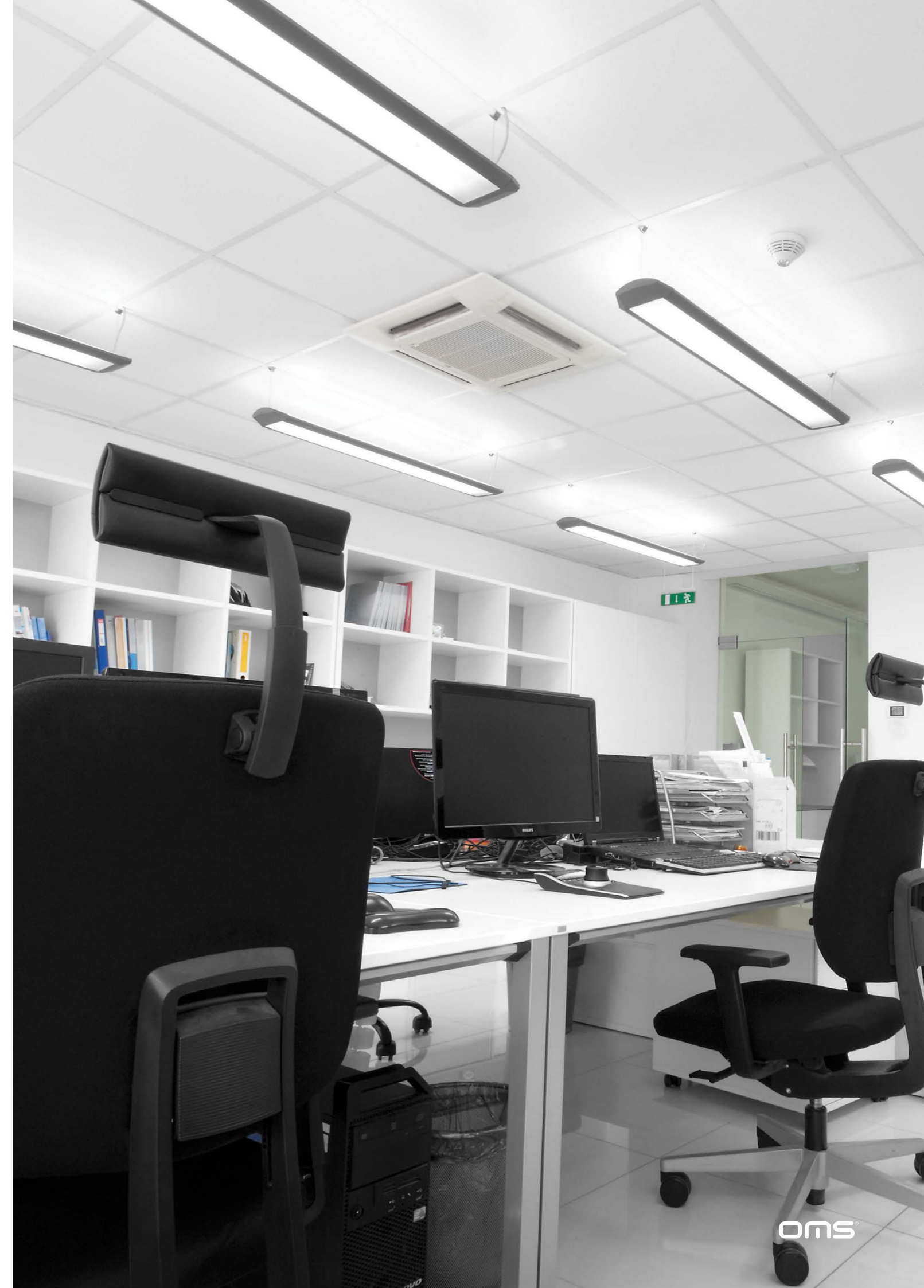

EMOTION

The light is able to substantially affect the ability of people to perceive, to change their mood, to arouse a feeling of visual and psychological well-being and to regulate the human circadian rhythm. This knowledge has enlarged the perception of the task of artificial illumination by a new dimension. Its role today is not only to illuminate the space but also to be effective biologically.

The scientific research during recent decades has substantially changed the view at the task of illumination and its influence on people. Light is able to fundamentally affect not only people's ability to perceive things around but also to change the mood, to arouse a feeling of comfort or vice versa discomfort and to regulate the human circadian rhythm. All this knowledge has enlarged the perception of the task of the artificial illumination by a new dimension – to be biologically active. When designing a lighting solution of an office space it is from understandable reasons inevitable to take into account both requirements equally. By mixing the light of various colours and utilising the ambient or accent lighting we can achieve the visual and psychological well-being of the employees without any negative influence on their regeneration capabilities.

LQS has a holistic approach to the illumination of spaces. It perceives its solution as a whole, with the goal to copy the properties of the natural light as truthfully as possible.



Work with light is something like an artistic creation. When the light designer masters it well, he/she is able to create a space where the employees will feel comfortable and happy.

AVAILABILITY OF DAYLIGHT

Working people spend a great part of their life in closed spaces. That is the reason why the quality of the artificial light is attributed extraordinary importance. As we have already mentioned on several pages, the scientific research has unambiguously confirmed the positive impact of the natural light on the feeling of people's visual and psychological well-being, their performance efficiency, the ability to concentrate and last but not least also the ability to regenerate. In most office spaces the requirement for availability of daylight is a

rule. The task of the artificial lighting is to fulfil the supplementary function or to replace it where it is fully absent.

The most important moment when planning the illumination for any space is a correct solution, the luminaire type itself is of second-rate importance, if it is able to ensure the required result. In general, it is valid that the human eye responds best to large continuous illuminated surfaces and the white diffused light reflected from the ceiling and walls. This type of illumination simulates the properties of the natural light in the best way.

The discovery of the third type of receptors in the human eye that are sensitive to the blue part of the light spectrum enabled the developing of biologically effective luminaires.

BIOLOGICAL FACTOR OF ILLUMINATION

BLUELIGHT CONTENT

Revealing the function of the third type of receptors in the human eye belongs among the biggest discoveries of the modern science. They are able to affect the production of melatonin, a hormone controlling the circadian rhythm of people. These receptors are sensitive to that part of the light spectrum which has the wavelength of 464 nanometres, i.e. the blue light. This knowledge became the basis for the luminaire producers – the lighting fixtures with a proper proportion of the blue part of the artificial lighting spectrum are able to affect the human activity effectively. From the point of view of evolution the blue light signals if it is day or night to the human organism. In the spaces with a limited access of daylight, its presence is a key factor that significantly contributes to the feeling people's well-being. Its shortage stimulates the production of melatonin and signals to the human organism that it is time for a rest and induces an increased need for sleep.

The absence of the blue light in the spectrum can lead to reduced performance and disruption of the circadian rhythm of the human organism. On the contrary, its correct ratio in the light spectrum from an artificial light source can stimulate the performance efficiency and positively affect the employees' feeling of well-being. From this point of

view especially the workplaces with a three-shift operation represent a challenge where a sufficient amount of the blue light is able to adjust the biorhythm of those employees who are working during the night shifts.

The proportion of the blue light in the light spectrum is subject to changes during the day. The correctly planned light solution can respond to this fact through simulation of the daylight.

The latest examination of the standard for the illumination of internal workplaces recommends a combination of direct and diffused lighting which is the most suitable for the offices. The suspended lighting fixture fulfils these specific requirements in full extent.

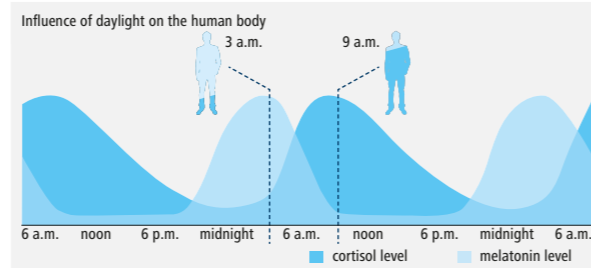

During morning hours the human organism produces the hormone cortisol which stimulates metabolism. Its concentration in blood reaches its maximum at about 9 a.m., then during the rest of the day its content continually decreases. Melatonin, also called the hormone of sleep, is produced by the human organism also during the night and its concentration in the human organism culminates at 3 a.m.

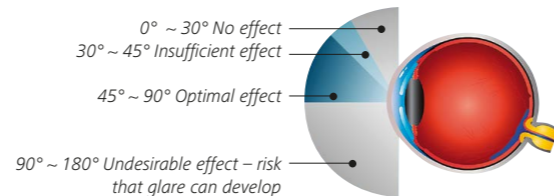

The third type of the photoreceptors in the human eye is sensitive to that part of the light spectrum which has the wavelength of 464 nanometres, i.e. the blue light. These receptors have influence on creating melatonin, a hormone controlling the circadian rhythm of people.

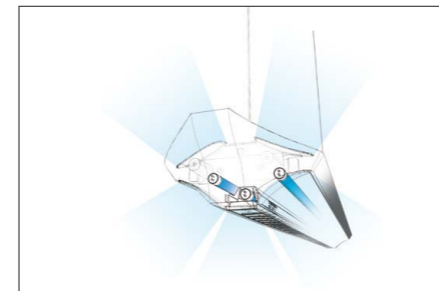

An innovative and compact design and a sophisticated mechanical structure enable this luminaire to direct the light in a biologically effective way.



An interesting luminaire design in terms of its ability to direct the light in a biologically effective way. The direct light directed from the LED sources located in the bottom part of the construction is completed by a microprismatic refractor that alters the direct light into soft, diffused light. The side optics are designed in such a way that it directs the blue spectrum of the light directly to the human eye under an optimal angle and affects the third photoreceptor responsible for correct operation of the human circadian rhythm. The positive biological effect of the luminaire would be especially effective with a very cold light with correlated colour temperature 6500 K.

Melatonin
Melatonin makes us feel drowsy, slows down bodily functions and lowers activity levels to facilitate a good night's sleep. It also ensures that a large number of metabolic processes are wound down. Body temperature falls; the organism, as it were, is put on the back burner. In this phase, the body secretes growth hormones that repair cells at night.

Cortisol
Cortisol is a stress hormone, produced from around 3 a.m. onwards in the adrenal cortex. It stimulates metabolism again and programmes the body for day-time operation. The first light of the day then stimulates the third receptor in the eye and suppresses the production of melatonin in the pineal gland. At the same time, the pituitary gland makes sure the body secretes more serotonin.

Serotonin
Serotonin acts as a mood-enhancing, motivating messenger. While the level of cortisol in the blood falls during the day in a counter-cycle to melatonin, serotonin helps us achieve a number of performance peaks. When daylight fades, the internal clock switches to night.

However, if our body does not get enough light during the day, it produces only a low level of melatonin. As a result, we sleep badly, we wake feeling unrested, we are tired during the day and lack energy and motivation. Insufficient exposure to stimulating light during autumn and winter can turn the process into a downward spiral. At that time of year, some people develop seasonal affective disorder (SAD). Their internal clock misses its cues because the hormonal balance in the brain is upset.

LQS VALUE

Biological factor of illumination

Biological factor of illumination	LQS Value of illumination
availability of daylight	0/1 (No/Yes)
blue light content	0/1 (No/Yes)
daylight simulation	0/1 (No/Yes)
dynamic lighting	0/1 (No/Yes)
tunable white	0/1 (No/Yes)

The natural light is not monotonous. It changes its properties not only in dependence on the season of the year but also depends on the cloudiness during the day. Its intensity and colour also change during the day.

DAYLIGHT SIMULATION

As we have mentioned several times, the scientific research confirmed that the daylight is the most typical type of light for people. The effort to adapt the artificial lighting to its properties results from this knowledge. That is the reason why, when designing the light system in the office spaces, we utilise the function of daylight simulation. The natural daylight is not monotonous. It changes its properties not only in dependence on the season of the year but it is also dependent on the cloudiness during the day. Its intensity and colour change during the day. All these factors affect our perception of the space and objects inside of it.

The daylight simulation can be achieved by various methods with the same goal: to achieve such an intensity and light colour that copies the properties of the daylight as truthfully as possible. At the beginning of the working hours higher illuminance with a high proportion of the cold light that will energise to a higher performance is desirable. On the contrary, during the lunch time it is suitable to increase the colour temperature and to strengthen the feeling of employees' relaxation. The afternoon decline can be avoided by increasing the proportion of the cold light which is replaced by warmer tones preparing the human organism for rest at the end of the working hours.

The daylight simulation is often implemented with the daylight sensor that assesses the lighting intensity in the room during the day and according to this it increases or reduces the luminaire output in the light system. In this way constant illuminance of the space in compliance with the standard is ensured during the whole day.

An assumption for simulating the daylight in the office spaces is the utilisation of the luminaires with the function dynamic light which can change the lighting intensity and tunable white which allows altering the correlated colour temperature in the room. The dynamic lighting in the luminaire is ensured by the DALI driver which is able to switch on or dim the light source from the value 0 % to 100 %. The function of the tunable white is ensured by two light sources radiating the light with different correlated colour temperature (cool white 6,500K and warm white 3,000 K). Through changing the output of individual light sources we can achieve various levels of the white colour temperature. E.g. at a 50% performance of both light sources the luminaire radiates neutral light with correlated colour temperature 4,000K. This solution enables creating illumination in the office space that corresponds to its task and emotional state we want to evoke in the persons who are present.

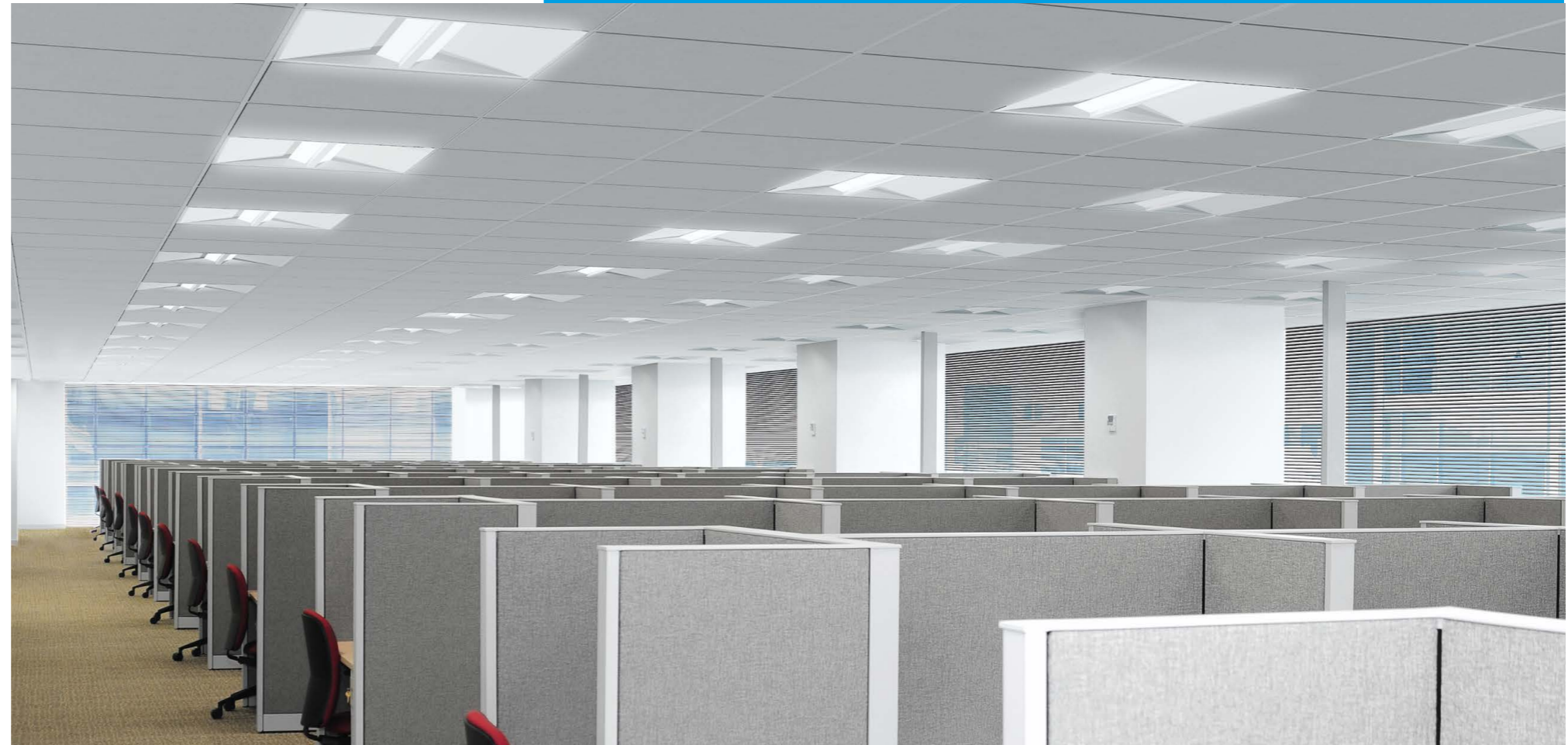

The goal of the daylight simulation is to achieve such a light intensity and colour that copies the properties of the daylight as truthfully as possible.

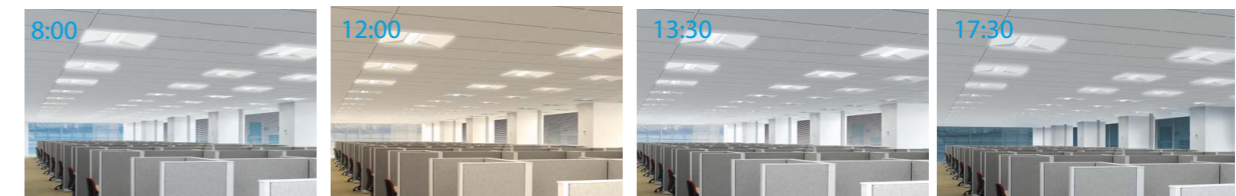

Good morning
Cool, fresh light raises the energy level of people coming into the office and provides a good start to the day.

Lunch time
A short rest helps us to recharge our batteries. The light level decreases and the warm light facilitates relaxation.

Post-lunch dip
After lunch, we usually feel sleepy. The light level rises again and changes to cool white to counter the „post lunch dip“.

Happy hour
Just before the end of the working day a change to cooler white light provides an alertness boost ahead of the journey home. For people working late, warm white light creates a pleasant „homely“ atmosphere.

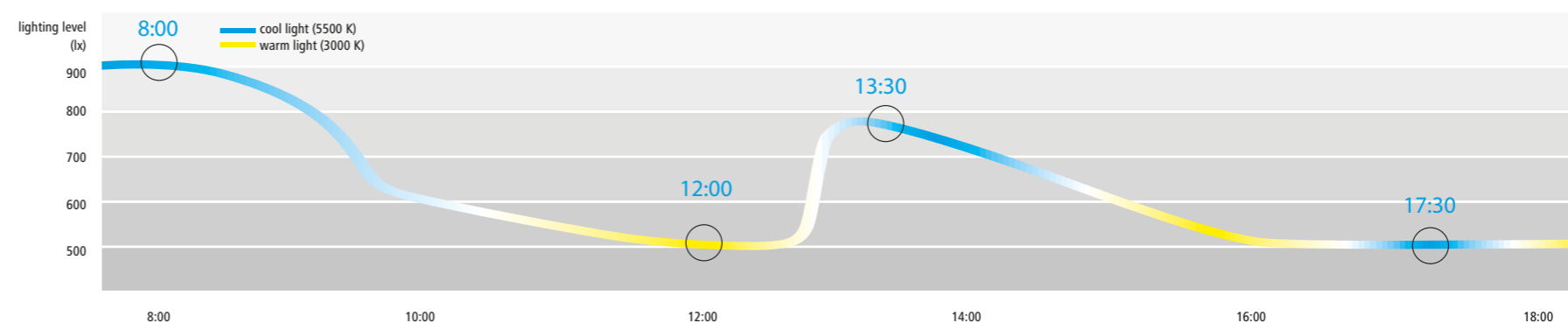

ILLUMINATION OF ROOM SURFACES

The recommended lighting of surfaces in the office space is bound to the general lighting of the workplace. Lower values the illumination of the wall and especially of the ceiling could make an impression of too much darkness and arouse a feeling of depression of the employees. On the contrary, when we illuminate them e.g. by luminaires with an indirect characteristic of luminous flux distribution, we achieve optical enlargement of the space and also improvement of the employees' feeling of comfort. In the case of lighting the surfaces in the office spaces, the summary of the British architects' recommendations known under the abbreviation LG7 (Lighting Guide 7) determines the standard. When defining them they proceed from the need of using the direct/indirect luminaires and reflected light, they define the recommended values of the surface reflectance and the space illuminance. From the point of view of lighting the surfaces in the space, LQS exceeds the requirements of these recommendations and places increased emphasis on correct illumination of all surfaces in the room.

LQS VALUE

Vertical illumination	
Vertical illumination	LQS Value
$E_{\text{avg}} > 0.5 E_{\text{Havg}}$ (Wall LG7) $E_{\text{avg}} > 150\text{lx}$	5
$E_{\text{avg}} > 0.5 E_{\text{Havg}}$ (Wall LG7)	4
$E_{\text{avg}} > 0.4 E_{\text{Havg}}$	3
$E_{\text{avg}} > 0.3 E_{\text{Havg}}$	2
$E_{\text{avg}} > 0.1 E_{\text{Havg}}$	1
$E_{\text{avg}} < 0.1 E_{\text{Havg}}$	0



Relative ceiling illuminance: min 30% of workplace illuminance

Relative wall illuminance: min 50% of workplace illuminance

Workplace illuminance 100 %

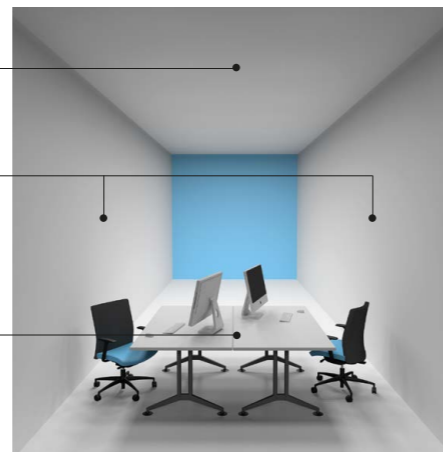

By a correct ratio of the illuminance of all surfaces in the room we can prevent both the psychological and eye fatigue and damaging the human sight as well.



The classical solution of the office lighting with recessed luminaires with a parabolic louvre ensures sufficient illumination of the workplace but the upper parts of the walls and the ceiling remain dark. Such illumination causes a feeling of a cave effect and makes the room optically smaller. Such a lighting system does not fulfil the LG7 recommendations.



The optimal solution involving types of the luminaires which are suspended, with both direct and indirect characteristics of the luminous flux distribution.



The new solution involving the latest types of the LED luminaires which are recessed, with direct and indirect distribution of the luminous flux direct part of the luminous flux towards the ceiling. The ceiling is sufficiently illuminated and the room seems optically larger. The space that is illuminated in this way fulfils the LG7 recommendations.

Vertical illumination

The vertical illumination which is based on the ability of the human eye to respond to the light falling from above plays an important role for the lighting of an office. Using luminaires emphasising the vertical surfaces, we achieve optical brightening and enlarging the space. It will enable the employees to recognise shapes and faces better and it will make their orientation in the space easier.

The vertical illuminance fulfils the LG7 demands and achieves 50 % of the working place's horizontal illuminance value. LQS assesses the spaces with satisfactory illuminance with 4 points.

A recessed luminaire with a strongly asymmetric radiation characteristic can be a suitable type of lighting fixture that meets the demands on vertical lighting of walls. If placed on the wall correctly (approximately to one third of the wall's height), the photometric luminaire characteristic will ensure a very uniformly illuminated wall almost from the top to the bottom.

Illumination of ceiling

In the framework of the space, the ceiling represents a large reflection area and therefore it is necessary to make use of its potential and to count on indirect luminaires when planning its illumination. The reflected light creates an impression of homogeneity and it most truthfully copies the properties of natural light. A suitable solution could be a recessed luminaire with direct and indirect distribution of the luminous flux and with the function tunable white. A protruding diffuser would enable directing part of the luminous flux to the ceiling and in this way to replace the traditional type of illuminating an area with a suspension luminaire.

From the point of view of LG7 the ceiling illuminance should achieve the amount of 30 % of the value for horizontal illuminance of the working surface.

LQS places even heavier demands for the ceiling illuminance and assesses the spaces with the ceiling illuminance of 75 lx with the score of 5 points.

LQS VALUE

Ceiling illumination	
Ceiling illumination	LQS Value
$E_{\text{Havg}} > 0.3 E_{\text{Havg}}$ (Ceiling LG7) $E_{\text{Havg}} > 75\text{lx}$	5
$E_{\text{Havg}} > 0.3 E_{\text{Havg}}$ (Ceiling LG7)	4
$E_{\text{Havg}} > 0.2 E_{\text{Havg}}$	3
$E_{\text{Havg}} > 0.15 E_{\text{Havg}}$	2
$E_{\text{Havg}} > 0.1 E_{\text{Havg}}$	1
$E_{\text{Havg}} < 0.1 E_{\text{Havg}}$	0

The emotional lighting creates the potential for utilising the lighting scenes and is able to induce relaxation, motivating and intimate atmosphere.

The ambient illumination completes the overall atmosphere of the space according to the customer's vision and the interior designer's as well. The accent lighting directs the attention to the selected object and emphasises its exceptionality.

EMOTIONAL LIGHTING

This category includes two different types of illumination which could be considered as opposites. On one side, it is the accent lighting which is able to emphasise or to draw attention to detail. On the other side, the ambient lighting gives the space overall mood and tone. Their task in the interior design is to induce the atmosphere and to emphasise the desirable detail.

The emotional lighting provides, from the point of view of its utilisation, many options in various types of interior and more and more frequently it plays an important role also in the framework of the lighting solution of the office spaces. It provides attractiveness to a prestigious office, it supports the functionality of the conference and meeting rooms, it adds interest to the communication zones. From the technological point of view, it provides a wide space for the utilisation of the RGB LED technology enabling the light colour to mix from red to violet. With RGBW, through adding the white colour, it is possible to achieve a more intensive saturation of the colour along the whole colour spectrum. The colour solution is thus strengthened by the potential to create various lighting scenes that are able to induce a relaxation, motivating or intimate atmosphere.

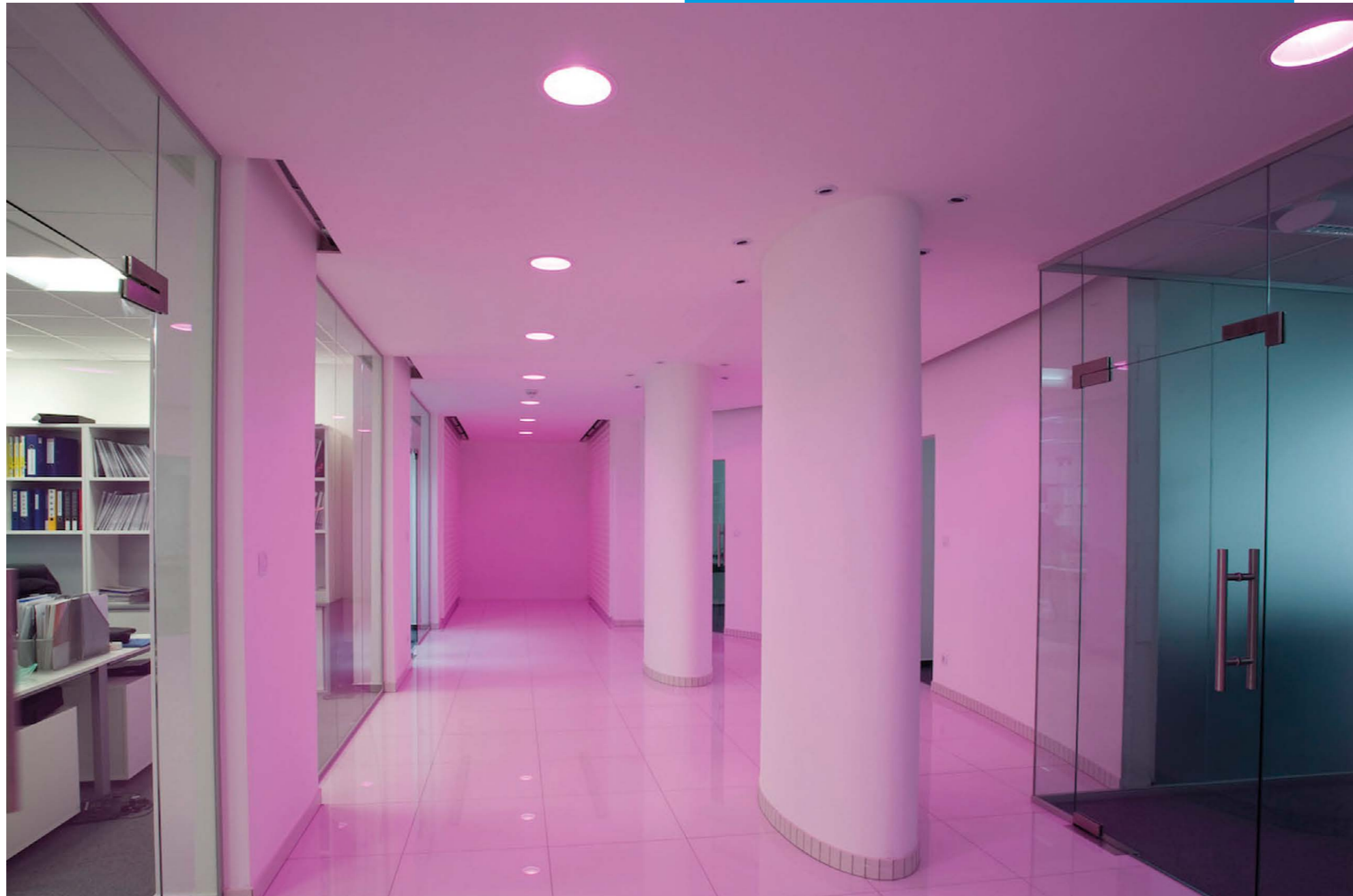

with the score of 5 points, the spaces without this type of lighting with 0 points.

Variable accent luminaires are able to attract attention to unusual details. Their conception is based on people's character to respond to various intensities of brightness. So, if we want to emphasise the importance of an object and to achieve the human eye detecting it and saving it as well in its memory as an exceptional one, we have to reach the contrast of luminance between the given objects and the background minimally in the ratio of 3:1.

Through the ambient luminaire it is possible to make the overall mood and space atmosphere complete. It is used for illumination of vertical surfaces, especially walls. It is often placed in such a way that it is not visible, e.g. to the soffits (e.g. the so called cove lighting). In this solution the light falls directly to the wall and creates an impression that its colour is changed.

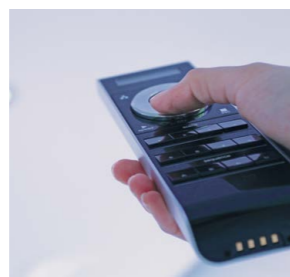

LQS VALUE

RGB colour mixing

RGB colour mixing	LQS Value
Yes	5
No	0

LQS assesses the spaces according to the fact if the emotional lighting is or is not part of the lighting solution. It assesses the spaces with emotional lighting

LQS VALUE

Ambient lighting

Ambient lighting	LQS Value
Yes	5
No	0

LQS VALUE

Accent lighting

Accent lighting	LQS Value
Yes	5
No	0

EMOTIONAL LIGHTING

The ecology and ecological solutions respecting the fragile equilibrium of the environment are important topics which have become key values across the whole industrial spectrum during the last decades. The manufacturers of the luminaires and light sources are no exception in this area.

Also in this line of business the demands on efficient utilisation of energy, the recyclability and long life of the products constantly rise. In the area of manufacturing the luminaires and the light sources, the effectiveness of the light sources, the effectiveness of the luminaires and their impact on the environment are more and more emphasised. These are categories which, besides the ecological approach, contain a substantial potential for energy savings and in this way also reducing the operating costs. For the developers and architects of the office buildings just this factor is the source of the strongest motivation when designing the light systems.



THE LATEST LAMP TECHNOLOGY

The times when the whole world applauded Thomas Alva Edison for the discovery of the light bulb are irrecoverably over. Although he made his mark on history forever as the inventor of artificial light, other scientists and inventors came after him and they shifted and are still shifting the development by leaps and bounds ahead.

With the knowledge about the limitedness of the energy sources which causes permanent increase of their prices, the trend taking into account the ratio of effectiveness of the luminaire or the light source and the consumed energy is coming to the foreground. As late as three years ago, the metal-halide lamps especially met these requirements but even they are retreating in favour of the light emitting diodes – LED. Compared to the conventional sources the LEDs achieve better parameters in each respect: they are more effective, they emit a negligible amount of heat, they place lower demands on the consumption of electrical energy, they do not contain mercury and so they are more ecological. In the area of manufacturing the light sources just LEDs represent a category which currently progresses most quickly. Up to 90 % of all innovations today take place in the category of the LED light sources. Of course, the development and production of

the conventional light sources has not been stopped but they progress more slowly. However, also here it is valid that the trend heads especially to manufacturing more effective and economical types of the existing light sources. The original types are replaced by the eco and

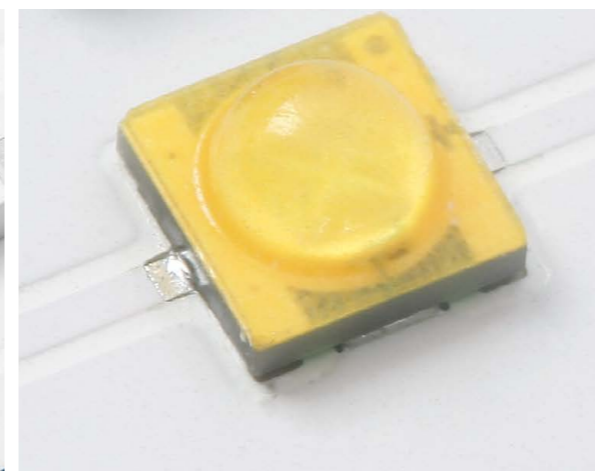
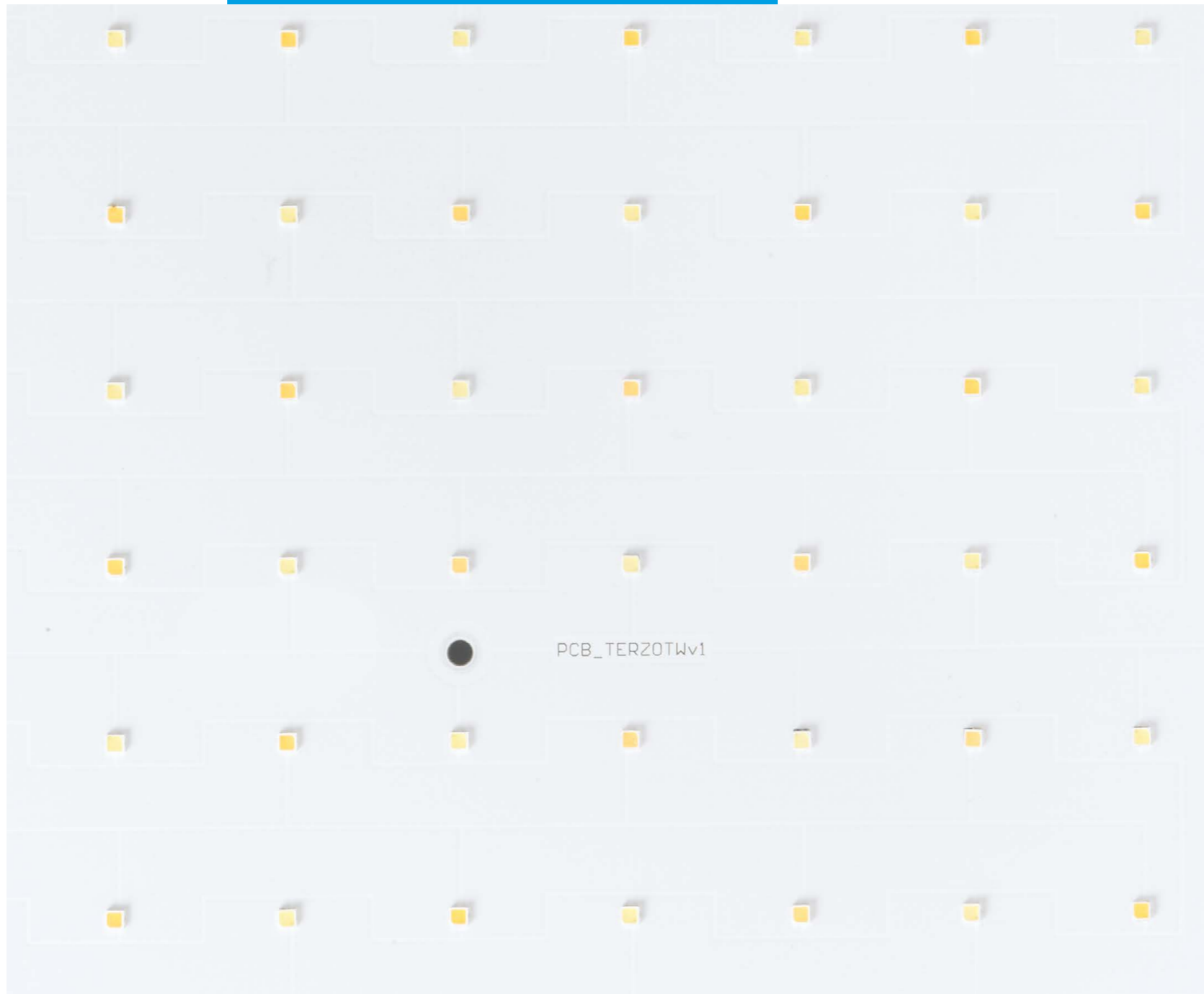

long-life fluorescent lamps or metal-halide lamps with ceramic burner of the second generation, etc.

The main indicator for selecting an optimal light source which a designer of the light system in an office building has to follow is the efficacy of the light source. Its value shows with what effectiveness electric power is changed into light, i.e. how much of luminous flux (lm) is produced from input power (W) delivered to a light source. The unit is lumen per watt (lm/W). The LED light sources achieve the best parameters also in this category. Currently the LED chips with efficiency of 160 lm/W at cool white CCT, are commercially available; however, in the lab conditions the value of 254 lm/W has already been achieved.

The higher price of LED luminaires is the reason why they have not replaced lighting fixtures with conventional light sources in spite of the fact they are obviously of higher quality. But also this factor is to be viewed in a wider context. Although the initial costs for purchasing of LED luminaires will always be higher, the return on investment in the form of energy savings during the whole luminaire life time and practically no maintenance costs make the LED luminaires extraordinary commercially interesting. From this point of view the retrofits where we only change the conventional light source for a more modern type prove to be only temporary and from a long-term point of view it is also a loss-making solution.

EFFICACY OF LIGHT SOURCE

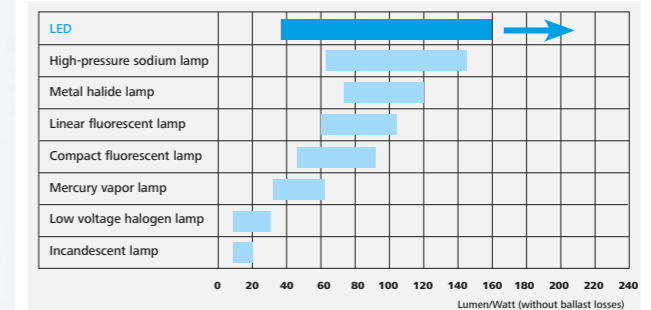

LQS VALUE

Latest lamp technology

Latest lamp technology	LQS Value
$\eta > 100 \text{ lm/W}$	5
$\eta > 90 \text{ lm/W}$	4
$\eta > 80 \text{ lm/W}$	3
$\eta > 70 \text{ lm/W}$	2
$\eta > 60 \text{ lm/W}$	1
$\eta > 50 \text{ lm/W}$	0

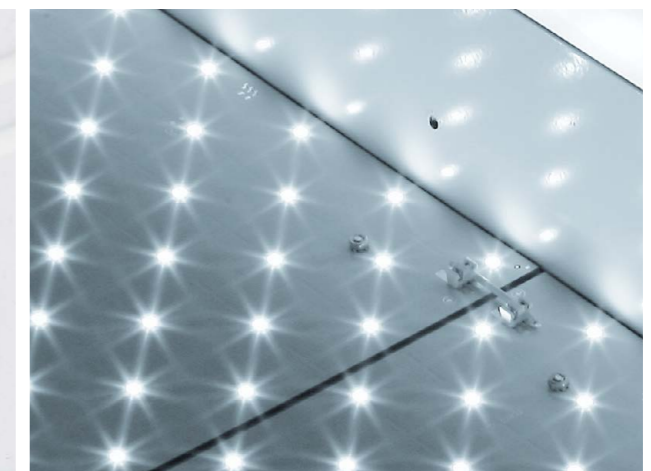

SYSTEM EFFICACY OF LUMINAIRE

The luminaire efficiency factor determines how effectively the lighting fixture itself is able to direct the light from the light sources with the smallest possible losses on the surfaces of the optical system. The light output ratio (LOR) expresses the ratio of the luminous flux flowing from the luminaire and the sum of the luminous fluxes of all light sources in the system.

$$\text{LOR} = \frac{\text{Lumen output of luminaire}}{\text{Lumen output of lamp}} \%$$

This value can be divided into the upward and downward ratio that expresses how many percent of the luminous flux from the luminaires heads to the upward and downward space (i.e. over and under the luminaire). This is of special importance for those spaces which place high demands on the illumination of the ceiling.

The materials used for luminaire production have the biggest influence on its efficiency. The optical materials enable changing the distribution of the luminous flux of sources, diffusing the light or changing the spectral composition. They are divided into reflective and

transparent ones. Aluminium, using various surface finishes, creates the predominant part of the reflective materials. The most often used transparent materials are glass and plastics. Aluminium, glass, plastics, steel have different reflectance and capability to absorb light. However, in general it is valid that the more effective the materials used in the optical system are, the lower the losses on these surfaces will be as well as the luminaire efficiency being higher.

$$\text{System efficacy of luminaire} = \frac{\text{Lumen output of luminaire}}{\text{Installed power of luminaire}} \left[\frac{\text{lm}}{\text{W}} \right]$$

Besides the used material themselves the luminaire efficacy is also affected by the design or the shape of the optical system. A correctly designed luminaire reflects the largest amount of light to the surroundings at minimal losses. The optimal mathematical and physical geometrical shapes of the lighting fixture can be calculated by modern computer systems.

LQS assigns the highest score the luminaires with efficacy of more 80 lm/W.

The luminaire efficacy factor determines how effectively the lighting fixture is able to direct the light from the light sources with the smallest possible losses.



It is approximately valid that for 2.5 W of the luminaire energy 1 W of the air-conditioning energy is used, i.e. if the energy consumption of the lighting system increases, the energy consumption for the air-conditioning operation grows in direct proportion, too.

THERMAL OUTPUT OF LAMP

The light spectrum visible for the human eyes is between the ultraviolet (UV) and infrared (IR) spectrum. In spite of the fact that the human eye is not able to catch the infrared light, it perceives it as radiant heat. Every object that is exposed to such radiation is constantly strained. However, the majority of the light sources used radiate this part of the spectrum in various extents. The lower the value of the radiated IR is, the more effective the light source is. From this point of view, on the bottom of the scale as the least efficient, there are the usual incandescent lamps which change up to 95 % of energy into heat and only remaining 5 % into visible light.

In the office buildings and offices with air-conditioning the light sources with a high IR radiation percentage are a sufficiently big load for the electric power consumption. The heat from the non-effective sources heats the air continually in the closed space cooled by the air-conditioning – this fact is connected with the need for a higher performance of the air conditioning. It is approximately valid that for 2.5 W of the luminaire energy 1 W of the air-conditioning energy is used, i.e. if the energy consumption of the lighting system increases, the energy consumption for the air-conditioning operation grows in direct proportion, too. The user of the office spaces illuminated by outdated light sources is burdened by increased costs not only for the energy needed for the operation of the light system but also for the air-conditioning.

From this point of view the installation of luminaires with light sources creating the minimal percentage of the IR radiation is considered the most economical. These requirements are currently reliably fulfilled by the latest LED light sources that radiate only a negligible amount of the IR radiation.

LQS assesses with the highest number of points those light systems which on average do not exceed 15 % proportion of the IR radiation in the overall radiated spectrum. This assessment is fulfilled especially by the LED light sources.

LQS VALUE

Thermal output of lamp

Thermal output of lamp	LQS Value
< 15% proportion of IR radiation	5
< 26% proportion of IR radiation	4
< 28% proportion of IR radiation	3
< 31% proportion of IR radiation	2
< 60% proportion of IR radiation	1
> 60% proportion of IR radiation	0

LQS VALUE

System efficacy of luminaire

System efficacy of luminaire	LQS Value
$\eta > 80 \text{ lm/W}$	5
$\eta > 70 \text{ lm/W}$	4
$\eta > 65 \text{ lm/W}$	3
$\eta > 55 \text{ lm/W}$	2
$\eta > 40 \text{ lm/W}$	1
$\eta > 30 \text{ lm/W}$	0



The life span of the light source is one of the key factors which the architect and developer should take into account when designing a light system.

DANGEROUS MATERIAL CONTENT

The vision of danger in connection with luminaires and light sources for common people is connected with the risk of cutting by a broken bulb. As a matter of fact, the risks connected with using some types of the light sources are much more serious and can have an impact on the people's health as well as on the quality of the environment. The reason is the mercury content, a heavy metal with high toxicity, which is an inevitable part of the fluorescent lamps and metal-halide lamps. In spite of extensive scientific research, until now we have not revealed a material which would replace the task of mercury in the light sources. The solutions which would not represent any risk from the point of view of safety are extremely costly and therefore unsuitable for the mass market.



The task of mercury in some types of the light sources remains thus irreplaceable. When the luminaire is switched on, a discharge arises during which ionisation of the mercury atoms develops and they subsequently emit ultraviolet radiation. This radiation excites the phosphorus molecules spread on the internal side of the fluorescent lamp and during their return to the original state they emit photons of visible light.

The risk connected with the light sources containing mercury does not consist in their common usage. It arises when they are broken during handling or they are not disposed in

compliance with legislation which defines the method how the used and damaged light sources containing toxic substances are to be removed.

In the first case there is a threat that the mercury vapours can leak to the air which in dependence of the number of disrupted sources, the size of the room and method of airing can cause the employees at the workplace short-term health problems (nausea, anxiety). In the second case, when disposing the toxic waste inadequately, it represents a long-term risk of soil contamination, as the heavy metals do not decompose and become a permanent part of the environment.

The designers of the lighting system for office spaces should also take into account the ecological potential of the light sources when they select them. The new types of the fluorescent lamps marked "eco" contain a smaller proportion of mercury than the older types. However, from the point of view of safety the LED light sources are undoubtedly considered the least dangerous option.

LQS assesses the light sources according to the mercury content and the highest score – 5 points are assigned to the light sources with zero content of mercury.

PRODUCT LIFETIME AND MAINTENANCE COSTS

When designing a lighting system of an office building one of the key factors the architect and developer should take into account is the lifetime of the light source and the costs for its maintenance.

These light sources wear off rapidly when they are frequently switched on and off. Therefore their placement e.g. in a corridor with an installed movement detector (most frequently due to saving of electric power) is not the best solution, just because of the shortened life span. The user of the space is then burdened by the costs not only for the purchase of the replacement light sources but also for activities connected with maintenance and service of the lighting system. Further indirect costs aroused by the need to make the space of the office building accessible during maintenance operations and not to restrict the everyday operation of the individual workplaces are connected with a more frequent replacement of the light sources.

Compared to the incandescent lamps the LED light sources represent at the first sight a more costly solution. Their price compared with the conventional light sources is really higher; however, their utilisation in the lighting system is profitable for several reasons. Their first and the biggest advantage is the extremely long lifetime reaching more than 50,000 hours and it represents at 11 hours operation time 250 days

during the year approximately 18 years. In the case of LED the end of the lifetime is given by the decrease of the light output on to 70 % (in some cases 50 %). At the same time they are light sources which show an extremely low failure rate, only two LED sources per million pieces produced. The regular costs for their replacement and maintenance are thus removed. By adding the functionality lighting management system into the lighting system we can reduce the need of the manual control which is also considered a certain type of maintenance. The long lifetime and minimal demandingness in the area of maintenance in combination with energy economy make the LED light sources an ideal solution when designing the lighting system in the office building.

When taking into account all relevant criteria, LQS assigns the highest score for the parameter "product lifetime" and the "costs for maintenance" just to those light sources with the lifetime of or higher than 50,000 hours.

COMPARING TOTAL COSTS FOR ILLUMINATION (TCO) TOTAL COSTS OF OWNERSHIP



	INDIRECT C-P PV L2	VEGA	VEGA (light sensor)	
type of light source	FSDH	LED CRI >80	LED CRI >80	
power consumption	55	55	55	W
number of light sources in luminaire	2	1	1	pc
control gear	ECG	ECG	ECG	
type of lighting control	none	none	light sensor	
lifetime of light source	10 000	50 000	50 000	hour
power consumption of luminaire	124	55	26	W
luminous flux	9 400	5 180	5 180	lm
LOR	41	70	70	%
luminaire light output	3 854	3 626	3 626	lm
number of luminaires	28	28	28	pc
average time when luminaire switch on between 6.00 – 18.00	12	12	12	hour
average time when luminaire switch on between 18.00 – 6.00	2	2	2	hour
number of days in week when luminaire switch on	5	5	5	day
price for electrical energy	0.18	0.18	0.18	€/kWh
purchase price of luminaire	45	180	190	€
purchase price of light source	3.5	0	0	€
purchase price of service hour	30	30	30	€
time needed for the exchange of one source	0.25	0.25	0.25	hour
COOLING ENERGY				
cooling system usage factor	50%	50%	50%	
cooling efficiency	2.5	2.5	2.5	Wh/Wc
purchase for initial installation	1 456.00	5 040.00	5 320.00	€
Number of maintenance required per 12 years	4	0	0	
Maintenance fee	406.00	0.00	0.00	€
power consumption of luminaire	124.00	55.00	26.00	W
power consumption of cooling system	24.00	11.00	5.20	W
completely power consumption of room	4 144.00	1 848.00	873.60	W
consumption of el. energy for	58.02	25.87	9.12	kWh
month	1 260.47	562.10	198.15	kWh
year	15 125.60	6 745.20	2 377.81	kWh
production of emission CO₂ per year	9 680.38	4 316.93	1 521.80	kg
price for el. energy per	10.44	4.66	1.64	€
month	226.88	101.18	35.67	€
year	2 722.61	1 214.14	428.01	€
difference between input costs		3 584.00	3 864.00	€
saving difference per year		-1 508.47	-2 294.60	€
saving CO₂ per year		-5 363.46	-8 158.58	kg
payback excluding maintenance		2.4	1.7	Years
payback including maintenance		2.4	1.8	Years

POWER CONSUMPTION OF LIGHTING INSTALLATION

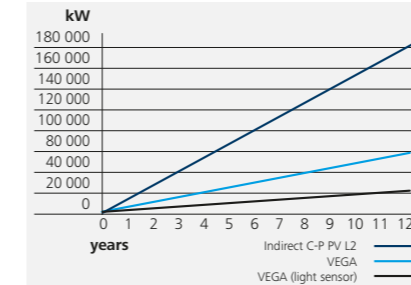

PRODUCTION OF CO₂

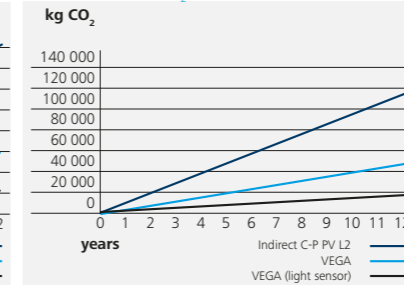

OPERATING COSTS AND PAYBACK TIME

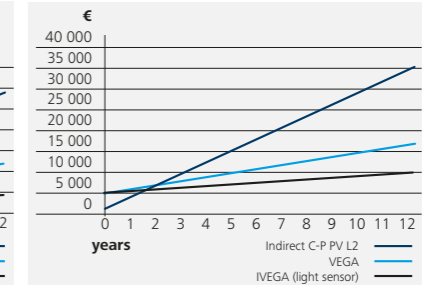

LQS VALUE

Product life-time & maintenance costs	LQS Value
TProduct life-time & maintenance costs	
≥ 50000	5
> 24000	4
> 19000	3
> 12000	2
> 10000	1
≥ 2000	0

EFFICIENCY

Nowadays modern technologies provide comfort for the light system control in the office buildings. The automatic control saves time, it enables selecting the adjusted lighting scenes by a simple control through buttons and at the same time it creates potential for energy savings up to 80 %.

To change the lighting intensity and the light colour in the room and to create varied atmospheres or emotions can be achieved today by a simple control of the button or a touch on the smartphone display. Today the technological progress enables the owners and users of the office buildings to take benefits from the quality illumination of the space and at the same time to save time, energy and costs for maintenance. Thanks to the intelligent forms of the lighting management system the operation of an office building can be more effective today than any time before.

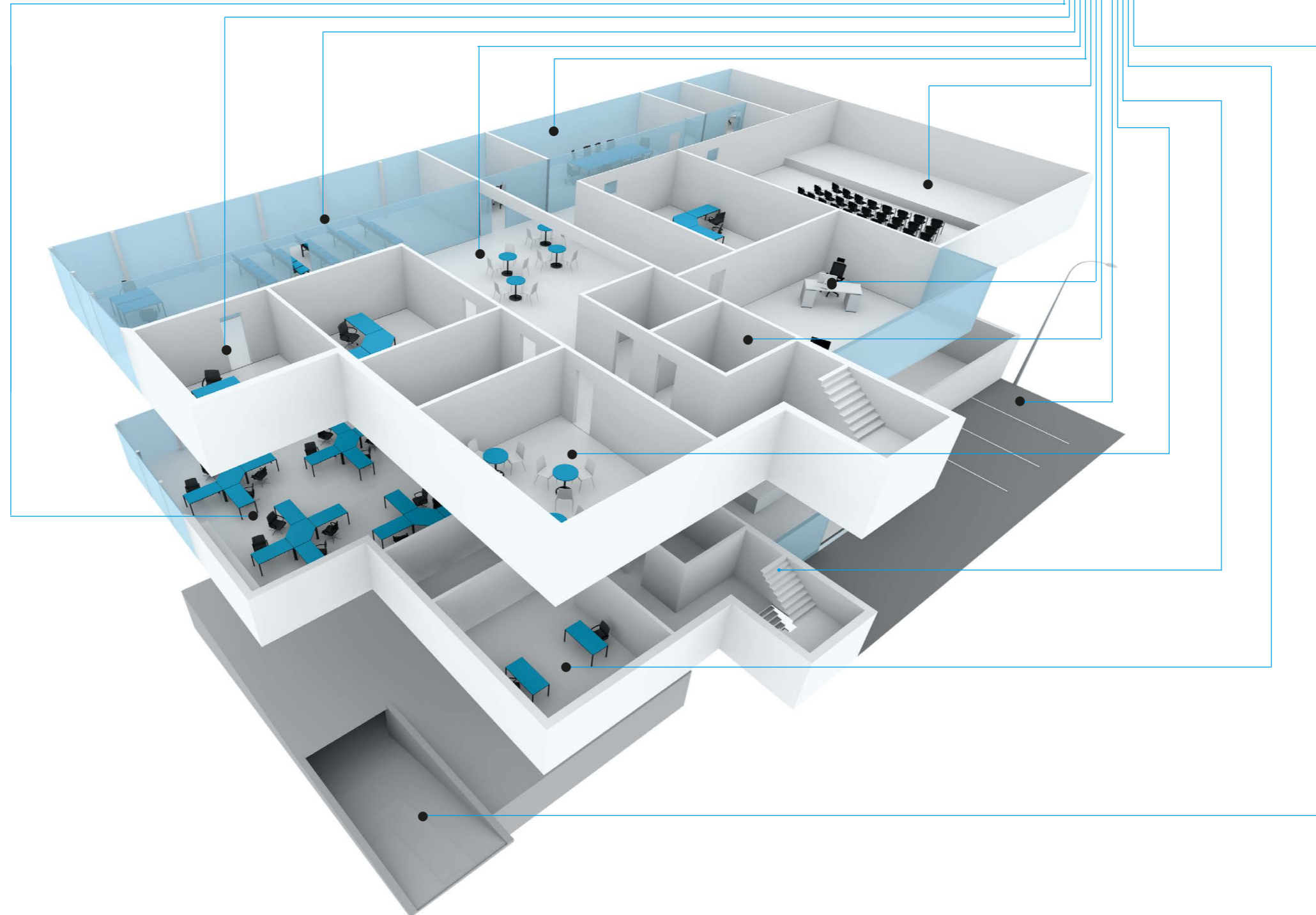

DAYLIGHT SENSOR

The daylight has decisive importance on the health and psychological well-being of people. Its shortage affects not only the quality of vision but also the performance efficiency and the ability to concentrate and can even disrupt the circadian rhythm. Therefore it is important to create such environment at the workplace which will be able to imitate the properties of the daylight as truthfully as possible. Although the majority of the workplaces have minimally one wall with windows, the availability of the daylight is never that optimal to be able to do without a high quality lighting system. The light conditions change during the day in dependence of the time of the day, weather and the season of the year. The task of the artificial lighting is to balance the differences and to complete or to replace in full extent the natural light when its availability is limited. The requirements for an adequate lighting intensity of the workplace can be achieved by installing the daylight sensor.

The control of the luminaires is carried out on the basis of the lighting intensity fully automatically and besides the energy savings also the user comfort is improved. Its efficiency is higher the more daylight falls to the given space. When installing the daylight sensors it is necessary

to pay attention to the fact the zones scanned must not overlap. Similarly it is unsuitable to place them in the reflection zone and the radiation sources which negatively affect the scanning process. An ideal case is to position the scanner over the task area which places

the highest demands on the constant lighting. LQS considers the daylight sensor the most effective technology from the point of view of energy saving and assesses the spaces with the daylight sensors with 2 points.

The requirements on adequate workplace lighting intensity can be achieved by installing the daylight sensor.

CONSTANT ILLUMINANCE SENSOR

The task of this sensor in the office spaces is to ensure constant illuminance independently of the state of the luminaires in the lighting system. The essence of this type of control results from the fact that the light qualities of the luminaires deteriorate during their installed lifetime, the optical parts are polluted or some lighting fixtures in the lighting system fail.

The constant illuminance sensor behaves in the space as the sensor of the light intensity and so it artificially adapts (decreases or increases) the luminaire luminous flux. For the sensor to be able to fulfil its function it is necessary to count on its installation already during the design phase of the lighting system which has to be over-dimensioned from the very beginning of the design. The economy of this solution can look contradictory at first sight. However, the reality is that it really occurs because during the first years of operation of the over-dimensioned lighting system the individual light sources do not run at full power. The system is adjusted to 100 % performance only when it starts to show signs of wear. In this way the constant lighting intensity of the whole scanned space is guaranteed.

From the point of view of the economy improvement, it is suitable to combine the constant illuminance sensor with the daylight sensor. In this combination both types of sensors are able to fully utilise the potential of the natural light falling to the space through the windows and to adapt the intensity of the artificial light to this situation. Combining several types of the lighting management system enables to make use of the natural light potential in full extent in the office spaces and to adapt the performance efficiency of the lighting system to it – this will prolong the lifetime and maximises the energy savings.

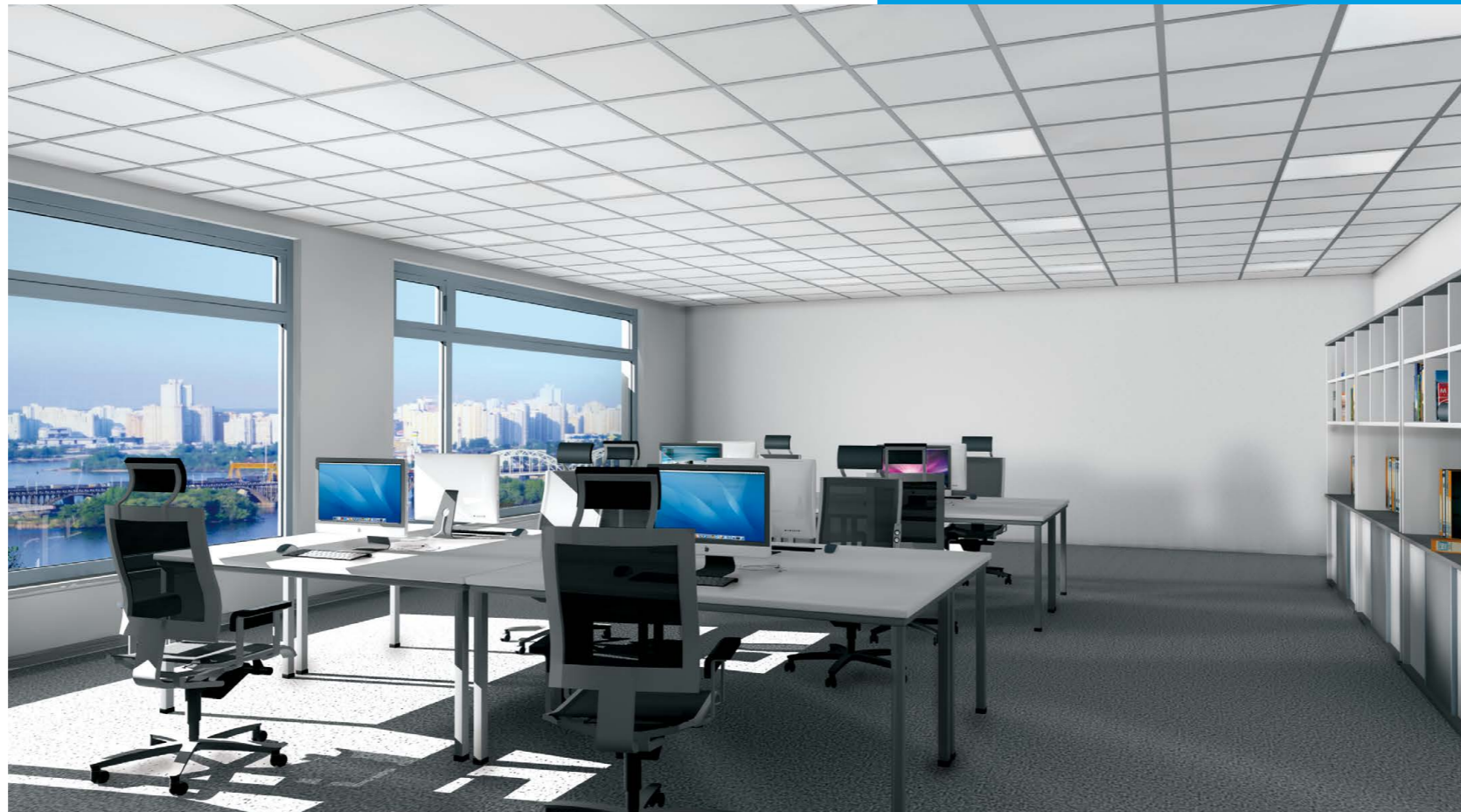

14:00 – 20%

The light conditions change during the day in dependence of the time of the day, weather and the season of the year. The task of the artificial lighting is to balance the differences and to complete or to replace in full extent the natural light when its availability is limited.

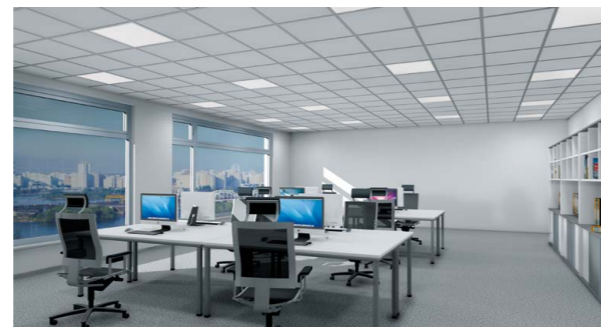

17:00 – 50%



20:00 – 100%

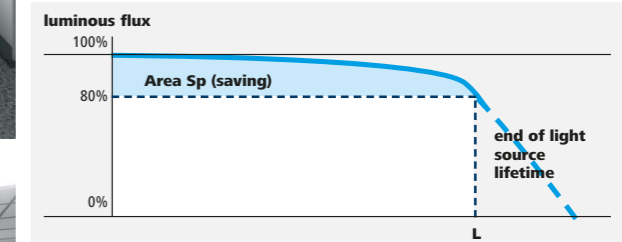

Every lighting system is over-dimensioned, minimally by 20 %. At the end of the lifetime it still achieves the required illuminance intensity. Using the constant illuminance sensor we can achieve 20 % energy savings during the first years of the lifetime.

The core of the system is the luminance sensor which reads the light conditions on the scanning level. The advantage is that the daylight and the artificial light complete each other, i.e. when the day lighting decreases, the artificial one increases and vice versa. This property ensures that in the given space there is always as much light as we really need. Such a regulation method can be carried out continuously or in leaps and the luminaires dim down to the value of 0 %. In the case of larger spaces several sensors are used. They assess the mutual resulting values by averaging.

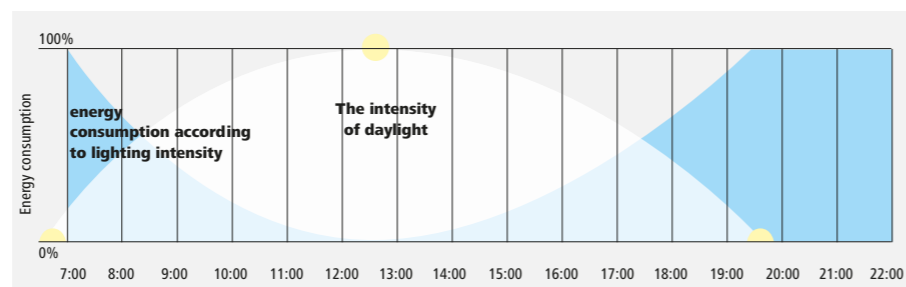

The energy consumption of the lighting system in dependence of the daylight availability achieves the maximum values early in the morning and during evening hours.

LQS VALUE

Daylight sensor

Daylight sensor	LQS Value
Yes	2
No	0

When installing the sensors it is important to pay attention to the zones scanned not to overlap and to be placed in sufficient distance from radiation sources which negatively affect their detection ability.

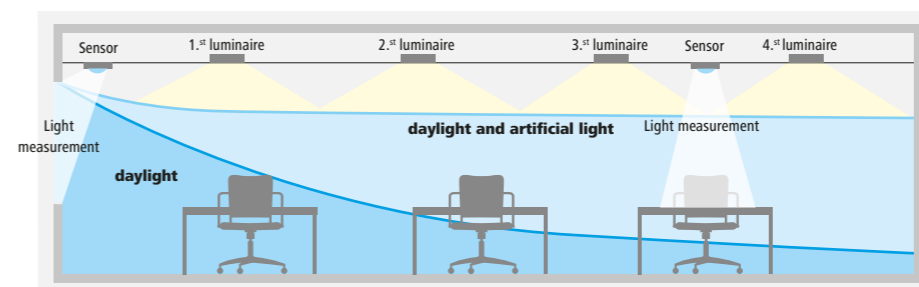

LQS VALUE

Constant illuminance sensor

Constant illuminance sensor	LQS Value
Yes	1
No	0

PRESENCE DETECTOR

In the framework of the office building there are spaces that do not require constant lighting. They are rooms, communication zones or underground parking lots without permanent occurrence of people and from the point of view of energy saving they represent a big potential. The presence detector represents a suitable type of control of these spaces. Its usage allows the luminaires to be switched on only when somebody appears in the space, i.e. only when the lighting is really needed. It is automatic control equipped with a sensor responding to the heat of the moving persons in the detection area. Scanning the space is ensured by passive infrared technology with built-in infrared scanners in the sensor which respond to the heat radiation emitted by the human body and transform them to an electrical signal. This sensor subsequently assesses the situation and switches on the illumination. The scanner itself does not emit any radiation and therefore we can speak about passive infrared sensors (PIR).

The presence detector can be used both in the indoor and outdoor applications with different sensitivity and mounting height. For an ideal coverage of the space, it is suitable for the sensors to be placed in positions where their scanning areas partially overlap. It is important to avoid installing the sensors close to street lamps, air-conditioning or heating units



The presence detector switches on the luminaires in selected spaces when somebody is present and thus the lighting is really needed.

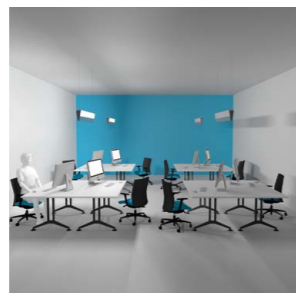

Sophisticated systems enable to adjust the presence detector in such a way that it will switch on the luminaires in that part of the room where the presence of the employee requires it.

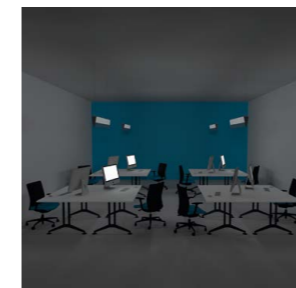
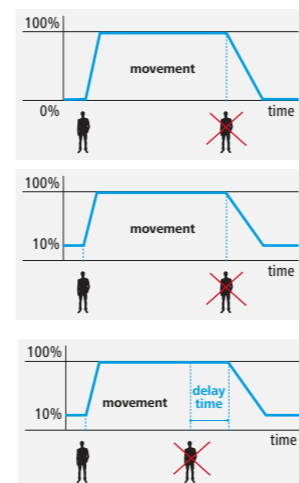

If there is nobody at the moment in the office or another office space, the presence detector switches off the lighting.

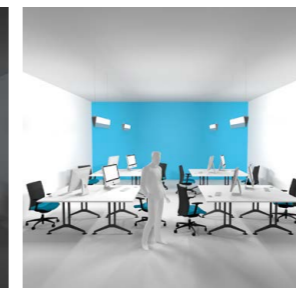

When an employee enters the room, the presence detector responds to the infrared radiation which the human body emits and switches on the lighting.

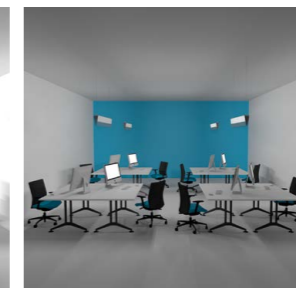

The presence detector can be adjusted in such a way that the lighting will not switch off in a vacant room immediately after the last person leaves it, but gradually.

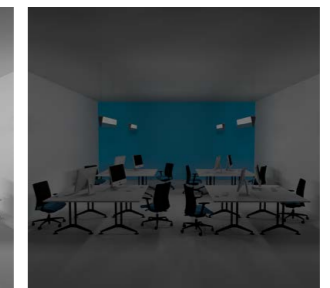

and other sources of intensive infrared radiation which could affect their functionality. When installed properly the sensor responds immediately after somebody enters the zone scanned.

When using control based on movement we can utilise the function of delay of dim down which means that the luminous flux of the luminaire does not change immediately after the movement detection dies down, but after passing the adjusted time without movement. This time is determined according to the type of the space and the frequency of the movement. The dim down can be transferred either to a certain level (e.g. 10 %) of the luminaire luminous flux or the process of dim down up to the value of 0 %. The level of the luminous flux amounting 10 % is used especially for safety reasons for no full darkness though without any movement to be in the space or due to the security cameras or prolonging the lifetime of the light sources, etc.

The movement sensor can be an independent action element (which controls the light system) or serves only as an input element that delivers information for assessment to the higher control unit or system.

From the point of view of LQS the presence detector represents an extraordinarily effective method how to increase the efficiency of the lighting system and to optimise the energy consumption therefore the spaces with this element in the lighting management system are assigned by the point evaluation 1.

LQS VALUE

Presence detector

Presence detector	LQS Value
Yes	1
No	0

PRESENCE DETECTOR

The lighting system control through changing the adjusted lighting scenes finds a wide implementation in the office spaces.

The adjustable lighting scenes represent an ideal tool of the lighting management system, e.g. in the conference rooms, representative areas or relaxation zones.

CALLING OF LIGHTING SCENES

Managing the lighting system based on the change of firmly adjusted lighting scenes finds wide implementation in administrative spaces. Under a lighting scene we can understand a summary of several adjusted factors which can be altered by a simple control through a button. Here belong: the lighting intensity (e.g. 100 %, 75 %, 50 %, 25 %, 0 %), light of colour (correlated colour of temperature), RGB scenes, calendar or simulation of daylight. Through causing a change of the lighting scene we can adapt the illumination to the actual needs of the workplace.

In the lighting systems with the LED luminaires we can adjust the lighting scenes using RGB mixing of colours. In the office building we can use this solution in the conference rooms, corridors, relax zones or representative areas. It can be controlled by a built-in board or through remote controls. In the especially structured spaces it is recommended to use the controls working on the wireless basis. The electromagnetic waves they emit are able to go through materials which form an obstacle between the sender and receiver. It enables building-in the receiver also in areas which are remote from the given room and controlling the lighting system also across walls on several floors.

The modern technologies currently enable to control the lighting through the iPad or smartphone. By creating a specific application we can touch-control the lighting system in the whole office space. Through wireless communication the selected controller emits a signal to the controller, it assesses it and through the control unit it sends directly to the luminaire or a group of luminaires the user remotely switch off, switch on, increase or reduce luminous flux or light colour.

From the point of savings the manual control does not represent such an effective solution as the automatic one.



LIGHTING SCENE 1:
A lighting scene where general luminaires emit warmer white light and accent luminaires are used to highlight special objects. This creates a more homely atmosphere.

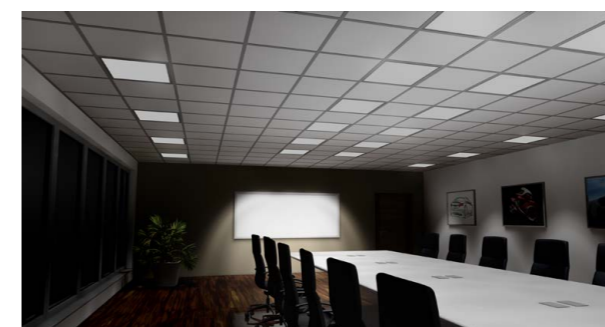

LIGHTING SCENE 2:
During whiteboard presentations, the corresponding lighting scene additionally illuminates the whiteboard and the cold colour stimulates higher performance.

LIGHTING SCENE 4:
For general meetings, the lighting provides comfortable illumination of the conference table and provides light to the walls and ceiling too, to create a pleasant atmosphere.

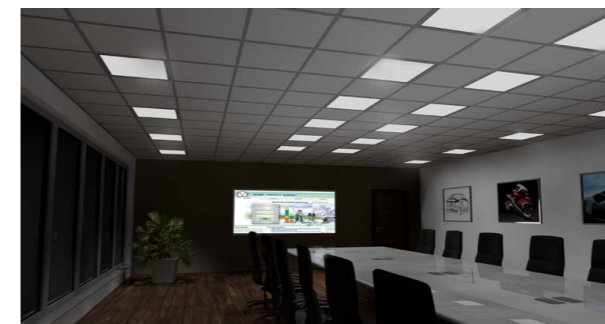

LIGHTING SCENE 3:
A lighting scene when we are watching a projecting screen. The general lighting is switched off.

SLE Central Power Source
The Central Power Source (CPS) belongs to the latest types of control. It is an innovative system with a centralised source of feeding for the LED luminaires. The CPS system is equipped with an intelligent communication interface between the central system (MASTER) and connected luminaires (SLAVE) which communicate with each other directly in the safe power supply 48 V DC system. Centralising the power supply source brings advantages in the form of a lower price for the LED luminaires which can be used without an electronic control gear, their smaller dimensions and also lower number of conductors is necessary. Thanks to the web interface implemented directly in the CPS it is possible to control, follow and adjust the luminaires to various scenes practically from any "web place". The DALI interface for ensuring the compatibility with older systems is also available. A big advantage of this control system is that during its installation the conductors and wires of the existing installation can be used.

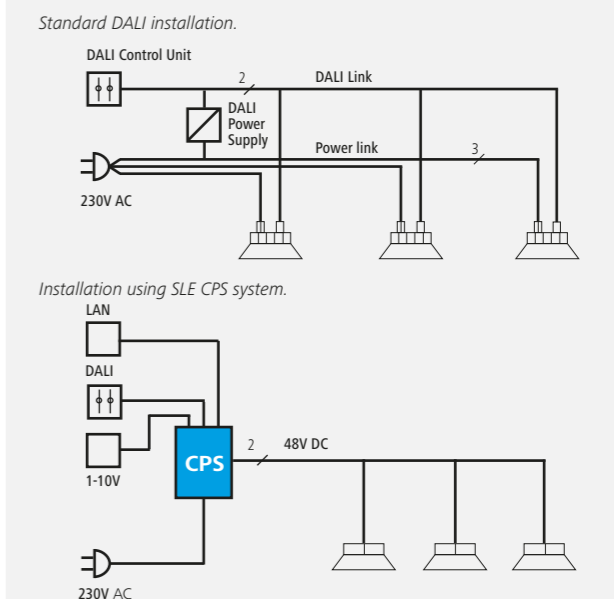
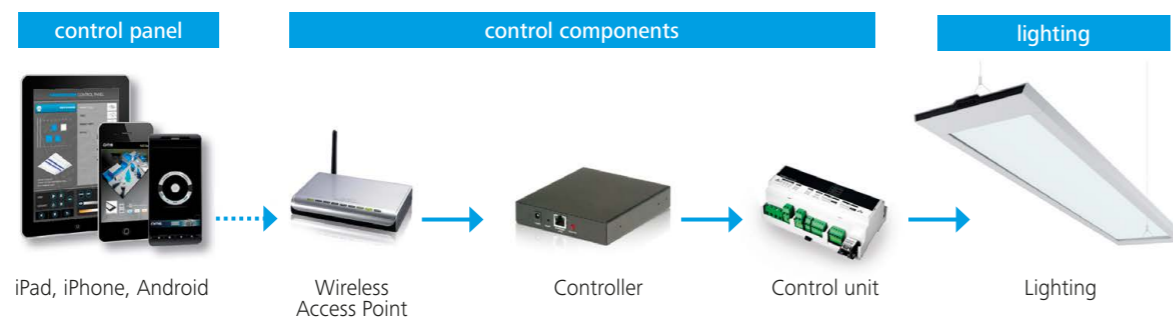

LQS VALUE

Calling of lighting scenes

Calling of lighting scenes	LQS Value
Yes	1
No	0

ESPRIT

People love flawlessness. Therefore the lighting producers do not take only their light and technical properties into consideration but also their overall design. Where an attractive look is combined with modern technology also inanimate objects acquire a new dimension. Let us call it esprit.

To breathe spirit into the inanimate objects is the basic ambition of the current industrial design. In the area of luminaire manufacturing it means the effort of the luminaire designers for an innovative connection of shapes and functionality. Today the modern materials and technologies enable countless numbers of variations which can be modified according to the client's vision.

The new, design dimension of the luminaire production has also been revealed by the designers and users of the office spaces. They do not only emphasise the functionality when selecting the lighting fixtures but also the ability to add interest to individual parts of the interior, to contribute to their specific atmosphere or to represent.

Although there are no quantifiable criteria for assessing the quality, it is important to respect a few rules in the creative process. They are as follows: overall impression of the luminaire, luminaire appearance in the room, detailed solution, surface finish, material of construct parts, functional elements.

We have responded to the design demands for the space illumination by creating an in-house department of research and development in the framework of which the "court" designers in collaboration with technical departments and the students of the Academy of Fine Arts and Design in Bratislava, specialisation industrial design, are working on the development of new design luminaires using the latest technologies. The result of this collaboration is series of the design and highly functional luminaires falling into the category of futuristic visions.



RACECOURSE
by Anton Zetocha

Luminaire is using „edge lighting“ principle. LED light source is placed in the middle of the body, which is working as a cooler, enlighting the plexiglass plate through edge. Special material ensures high homogeneity of enlightened surface, which distributes light into the room. With this technology the luminaire can be very thin. When switched off, luminaire is transparent and blends with the room. This is one of possible ways of future lighting, based on minimalistic design using a LED light source.



CIRCLE
by Matúš Opálka

Microclimatic conditions including noise, colour workplace requirements and area illuminance are the main factors creating a quality work environment. The product offers direct or indirect light source, both with built-in air purifiers - ionizers. The ribbed surface promotes better air circulation and comfort while reducing noise.

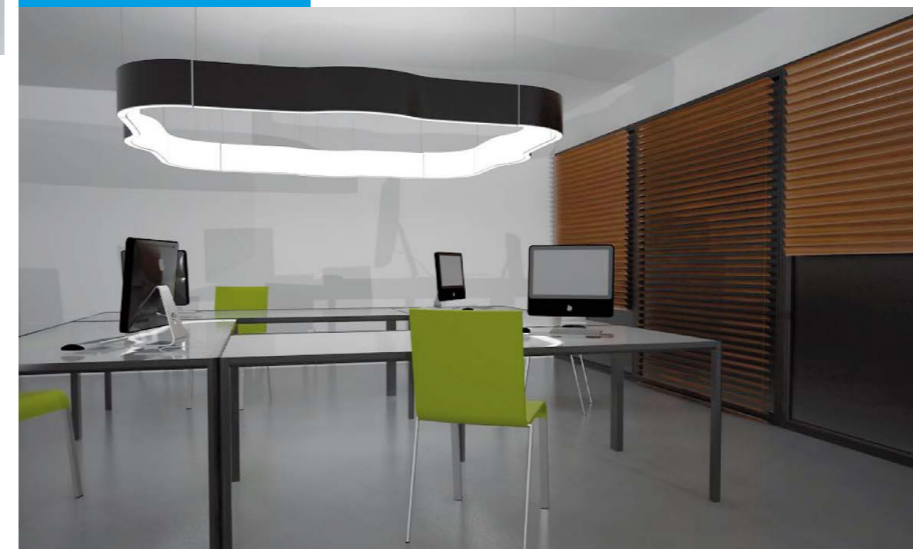

MEANDER
by Lenka Abonyiová

The designer concentrates simultaneously on biologically effective lighting and the need for social sharings. He says: „I share the blue light content from my product (luminaire) together with my colleague to help him improve efficiency forming the social bonds.“ A wave epitomises an effort of distinguished natural design of the luminaire making direct impact on consumers together with the light path.



EXCEPTIONALITY

SLE's ambition is to create smart lighting solutions that bring added value and wellbeing to our lives in addition to showing respect for the environment. To this end we act as a lighting solutions project platform, focused on connecting everyone involved in lighting in mutually beneficial collaboration under the umbrella of SLEs knowledge, tools and services. In this way, each participant can contribute their unique skill set towards a cooperative final solution of higher value and quality than could be achieved alone.

This chain of value is what sets SLE projects apart, acting as a simple and reliable framework upon which our partners can stand with confidence. Furthermore, we understand that a successful business strategy must be customer focused, and SLE's support enables partners to be just that, because we have the rest covered.

WHAT SETS IS APART

Our partners can come to us for exclusive products, full solution packages, comprehensive yet simple sales support and cutting-edge information, which together help us achieve the collective goal of putting the future of lighting into practice now to provide a better future and achieve business success.

Exclusive products

Our distinctive product portfolio offers cutting-edge products that cannot be found anywhere else and which are guaranteed to perfectly integrate with every solution we provide. And as each product is designed for specific applications, our partners can rely on finding the best fit for every lighting design and project. Furthermore, with the possibility of product customisation, both partners and customers are assured that every solution is truly specialised and therefore unique and worry-free.

Complete solution packages

Lighting can be complicated, especially considering the influx of new technologies, terminology and possibilities. This creates stress for both customers, who do not understand their possibilities, and lighting professionals who must navigate a myriad of options to find the best solution. With this in mind, we offer a range of complete 'ready-made' solutions for every application, to keep things simple for everyone but never at the expense of quality or suitability. Each solution includes everything needed for the implementation and completion of each project and even comes with added benefits.

Moreover, as each solution is provided as a whole, full compatibility of all components is guaranteed, and the entire system falls under one straightforward warranty. To help partners communicate these solutions, we provide understandable and transparent information that makes it very easy for customers to grasp the options and make an informed choice. In this way, lighting suddenly becomes very simple.

Each complete solution package contains:

- Lighting services
 - Lighting audit
 - Luminaire selection
 - Definition of illumination
 - Lighting calculation
 - TCO calculation
 - Standard wiring design
 - Lighting measurement
 - Energy measurement
 - Customer presentation
- Luminaires
 - Dimmable LED luminaires
 - Luminaire package and transport
- Support
 - Transport
 - Lighting installation
 - LMS adjustment
 - LMS training
 - Electrical installation approval
 - Recycling of old lighting installation materials

We tailor our services and support to current and future market needs, thereby increasing the effectiveness of every link in the value chain, from supply to end use.

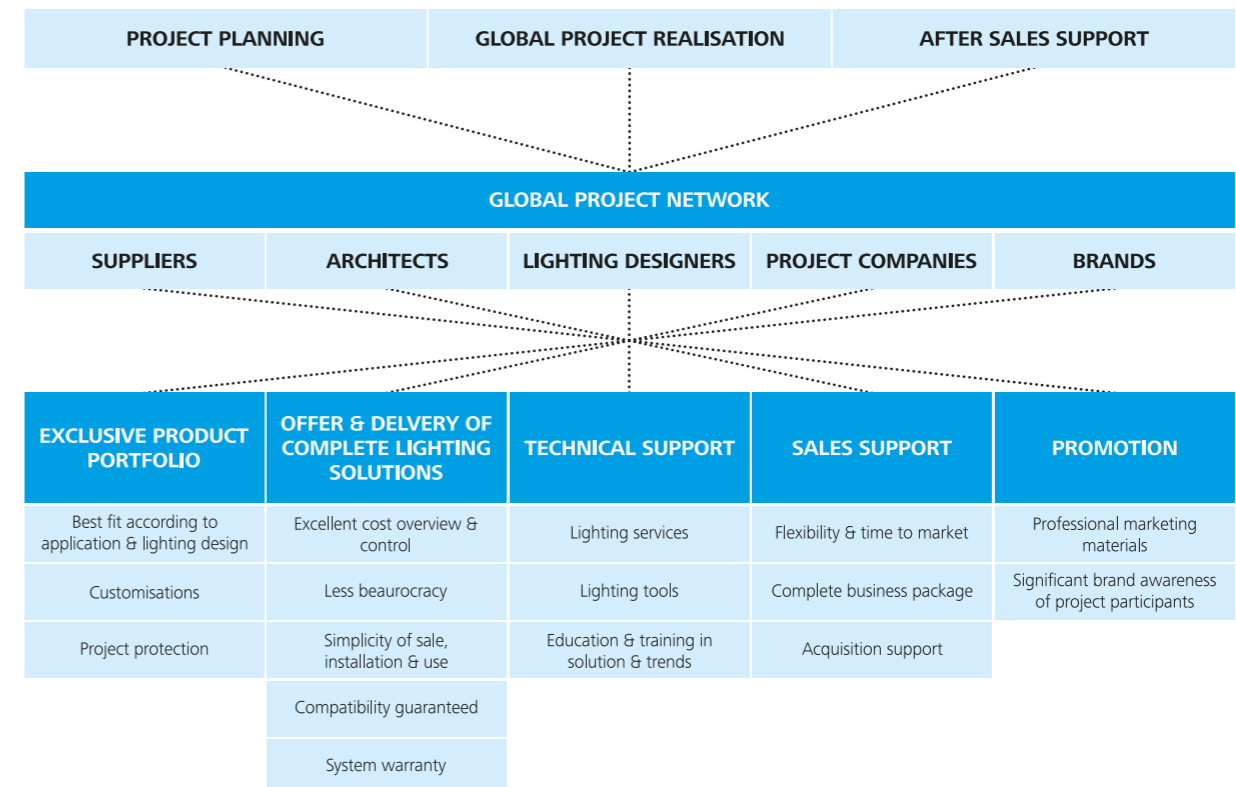

Sales support

Our partners' realisation is at the heart of our interests, which is why almost everything in the SLE value chain is useful for those on the front line. From technical support tools through product information to marketing materials and project promotion, we provide everything needed to achieve sales success. And once a sale has been made, we will also help with acquisition and financing, giving customers a name they can trust in and taking the extra load off our partners. With such a complete business package, our partners will never be short of help in attracting and building a firm and long-term relationship with customers.

Technical support

We have created a framework of clear and accessible knowledge, practical and theory-based support, and insights into the development of lighting through research. To achieve this, we eagerly follow the trends that are driving technological and ecological development in the global market and apply them to lighting and its influence on both humans and the environment. This knowledge is implemented both through our own lighting services and in the

development of a number of specialised proprietary supportive tools for all involved in sales, project planning and implementation. These tools include the Lighting Quality Standard, described earlier in this publication, and its associated software tools LQS Composer and LQS Composer PRO, in addition to LIACS, Saving in 5 and the Right Light books, one of which you are reading right now. For more information about these tools and how they can help you, visit the SLE website.

Promotion

It is no fun doing the work and never getting any credit, which is often the case for the individuals and small companies involved in the provision of lighting solutions. We believe that everyone involved in a project should be given due recognition. All partners involved in our projects are included in related promotion. This strengthens both the presence of truly skilled professionals on the global lighting scene and the network of support and collaboration that will drive the success of all.



LIGHT IN OFFICE

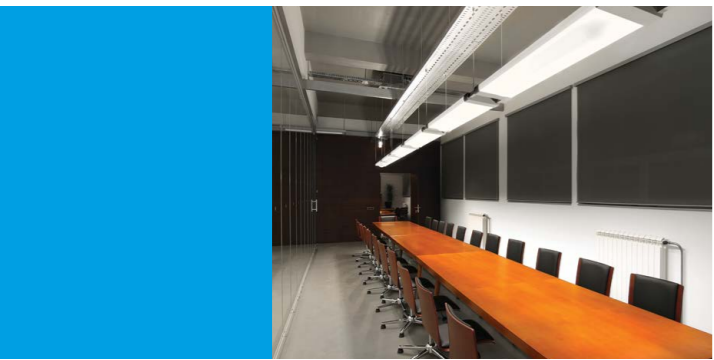



The entrance space is an advert for all office premises. The emphasis is placed not only on the functionality but also the representative character of the lighting solution.

In all entrance halls with high ceilings it is suitable to use the suspension luminaires. The design lighting fixture REBEL developed by the company SLE represents an ideal solution for this type of the space.

RECEPTION OFFICE AND FOYER

The entrance space is an advert for all office premises. It is the place of first contact based on which we create an impression about the character of space.

The basic level of illumination determined for these types of spaces by the technical standards is not by far the only criterion that is to be taken into account when planning the illumination today. The emphasis is placed not only on the functionality but also the representative character and creativity of the lighting solution.

The correctly chosen vertical and horizontal lighting of the entrance spaces increases the visibility and makes orientation in the space easier.

The space of the reception office is to be illuminated by a suspended luminaire which is attractive from the point of view of design. The ambient light of the reception desk by the LED modules in combination with a transparent material contributes to increasing the space attractiveness and creates a positive communication atmosphere.

The type of the reception office with a permanent duty places specific demands on the illumination. From the point of view of selecting a correct type of the luminaire which copies the needs of the office and the workplace, it is suitable to complete the lighting in the task area by a desk or freestanding luminaire.

The ambient and wall luminaires or luminaires with a

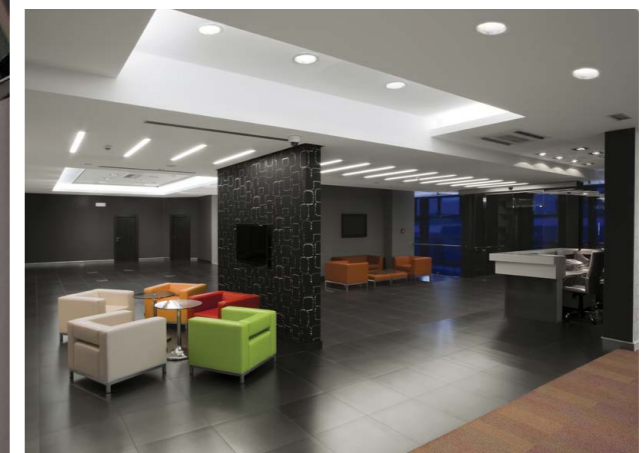

For the main lighting of the reception area we can use recessed luminaires with a direct characteristic of luminous flux distribution and luminaires with narrow beam angle (spotlights).

The accent lighting or luminaires with an asymmetric radiation curve can be used for the illuminance of the logo. When designing the lighting system for the entrance spaces and reception office we not only emphasise the requirements of the standard but also the representative character and creativity of the light solution.

narrow beam angle of radiation are able to create interesting light effects in the entrance space and to contribute to its plasticity.

The recessed floor LED luminaires help people to orient themselves in the space, they

copy the communication paths; make the entrances and doors to other communication zones visible.

By building-in the intelligent lighting management system we can correct the intensity and diversity of the lighting scenes

in the reception area, to adapt various time intervals to their needs and to achieve in this way, not only an effective illumination in this part of the office space, but also the optimal energy consumption.





OPEN SPACE OFFICE

The open space offices with an open disposition, an area achieving often hundreds of square metres, determined for minimally 6 persons are a favourite solution especially in modern technological companies emphasising the effective utilisation of the space.

The open space office, an office without any internal dividing walls and doors creates conditions for immediate conversation and feedback between the employees. It enables them to cooperate more effectively and at the same time it satisfies the natural necessity of people to create social ties. In spite of the missing construction boundaries, the open space office is often a distinctively segmented space. However, the hierarchy of the individual zones is not determined by walls but ergonomically correctly deployed furniture which delineates the space for the management, leading employees, individual working groups and at the same it defines the communication zones. The differentiation of the working and communication zone can be achieved by adapting the luminance distribution level to the room organisation or the furniture. The desks, e.g. require different level of lighting than the general office space, the requirements of the lighting uniformity are also different. These values are defined by the European standard EN 12464-1.

Also the lighting system has to be adapted to the structure of the space in the open space office. In general it is valid that the illumination in an open space office should be uniformly distributed without any places with a distinct light exposure or shadow. As a rule, the open space office is a place of meeting various information technologies requiring a high rate of concentration from the employees. Selecting a correct



To achieve the constant visual conditions we use the floor luminaires which directly illuminate the task area. A correctly selected correlated colour of temperature can create optimal conditions for stimulating and concentrated work. The light with neutral white colour and correlated colour temperature of 4,000 K is recommended, however, the maximal visual well-being of the employees is best achieved by the simulation system of the daylight.

Besides the correct lighting of the task area it is also inevitable to pay attention to the vertical illumination which fulfils its task when we orient ourselves in the space. The luminaires with asymmetric radiation curve, e.g. the wall-washers. This type of illumination enlarges the space, people feel better, more relaxed and safer inside of it.

As a rule, the open space office has a wall with windows directed southwards which are exposed to the permanent influence of the daylight. Therefore for the most effective lighting the daylight sensor is recommended. Their optimal combination can achieve savings up to 68 % in the open space office. However, the great number of glass surfaces at the same time represents a risk of an excessive glare of the workplace and therefore we have to consider an adequate system of shutters. Their control can be ensured by the system KNX building management subsystem. It is an integrated management system of all electric installations in the office building enabling the user the remote control of the lighting system, shutters, security cameras and alarm, heating, etc.

luminaire and light source will help to reduce the tension of the eyes when we shift the attention from the screen to the working area and surroundings. In this way it helps to improve the performance efficiency and prevents possible health problems of the employees. The suspension luminaires with direct and indirect light distribution that copies its natural properties most truthfully are most suitable for the general lighting. The indirect diffuse light they emit helps to model objects and to orient oneself in the space better. At the same time, it reduces the indirect glare when the light reflects from the PC screen or other shiny surfaces in the room.

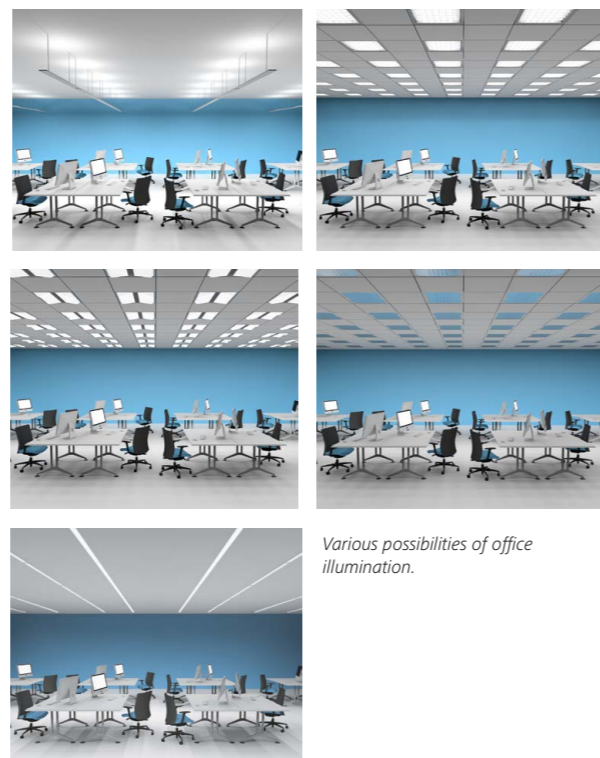

Various possibilities of office illumination.



The lighting system has to be adapted to the structure of the space in the open space office. Increased demands are placed on the lighting uniformity that should prevent a strong exposure and rise of sharp shadows.



CELLULAR OFFICE

This is an ideal solution for small working teams of maximally six people, carrying out activities demanding on concentration, with an office agenda that requires storage space or for employees who come into contact with confidential information. In dependence on the office type when we select the illumination the emphasis is laid both on the functionality and the representative character.

A well-designed cellular office provides the employees several advantages at the same time thanks to its limited size. It gives the impression of greater intimacy, it enables a direct approach to the windows, the availability of the daylight and so, on the whole, it creates a "more individual" space for the "light well-being management".

The selection of the correct type of the lighting system of this office space type depends on the orientation and structure. In general, the recessed luminaires are considered the most economical lighting solution. The suspension luminaires with the direct or indirect luminous flux distribution are considered a more comfort and attractive solution which are able to optically induce an impression of a larger space even in small offices and in this way to help to create an almost homely atmosphere of the workplace. The accent lighting will make the details referring to the corporate culture visible; the ambient lighting will enlarge the room optically and will

create an impression of an open space.

In a cellular office accessible for the public, the usage of luminaires with an interesting design which in a suitable combination with the floor luminaires are able to complete the atmosphere of the whole space architectonically and from the point of view of the design appear to be especially effective. Similarly as in other types of the office spaces we must not forget about the illumination of the vertical areas in the zones demanding on reading or precision work.

The installation of the daylight sensor can achieve up to 60 % savings of the electric energy consumption in this type of office.



A correctly selected correlated colour temperature can help to create optimal conditions for stimulating and concentrated work. The light with a neutral colour and correlated colour temperature of 4,000K is recommended for the offices; however, the maximal visual well-being of the employees can be fully achieved by the system of the daylight simulation.

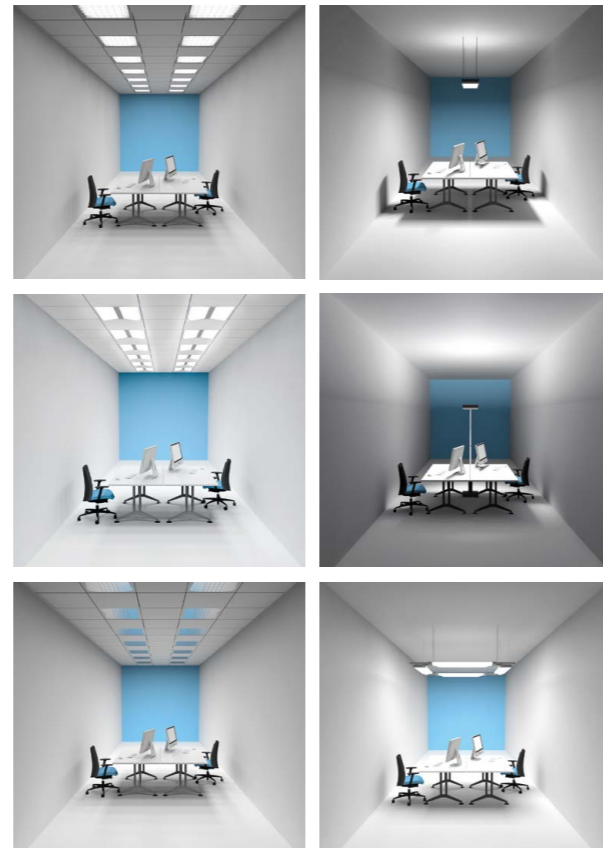

Various options for cellular office illumination.

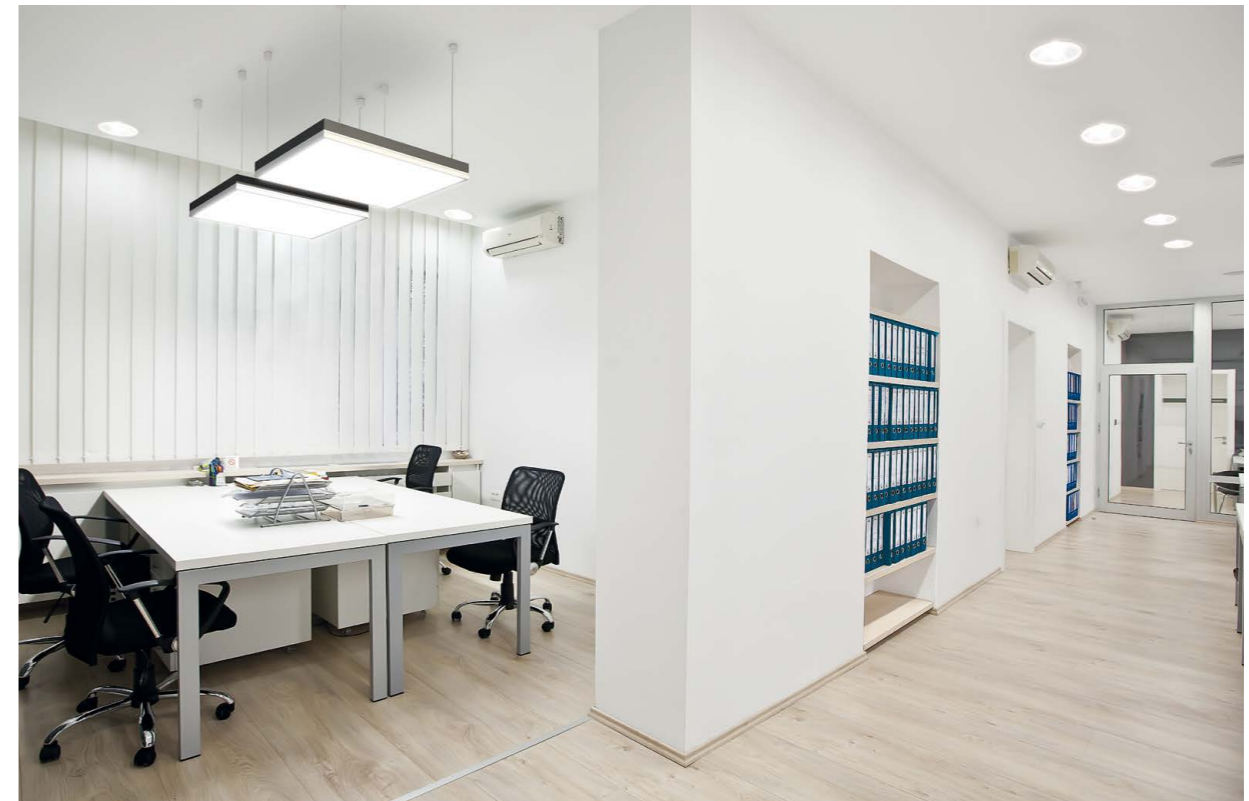



The head office is a multifunctional space. It provides a background for concentrated work as well as for informal meetings and therefore it requires a variable solution of illumination.

HEAD OFFICE

Almost no other space in the office building offers the designers and architects such a creative potential as the "head office". Its task is to create conditions for work of the leaders, to set up a background for their meetings with colleagues and at the same time to represent the company or corporate culture.

The natural architectonic structure of this office type automatically includes the inevitability to expect not only functional but also designer above-standard furnishing of the interior and illumination solution as well.

The illumination of the desk places demands - besides the functionality - also on an inventive and representative design and it has to fulfil all parameters necessary for a concentrated activity. This space allows showing the suspension luminaire to good advantage which attracts by an exceptional design and modern technological parameters. The optimal distribution of the luminous flux without striking transition lines in the immediate proximity of the desk will prevent the wear of sight and feelings of fatigue.

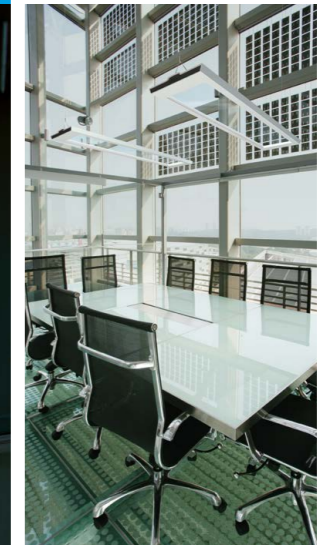
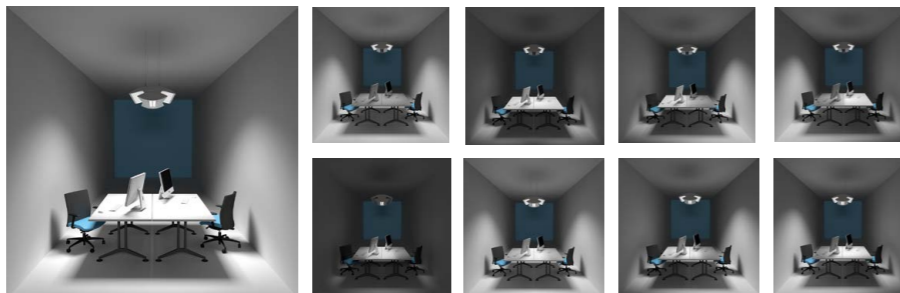

The conference part in the prestige office requires a different type of light solution. The balanced light in warmer colour shades gives the human skin a more pleasant and natural appearance.

The overall visual impression from the prestige office is completed by the programmable lighting management system with the adjusted lighting scenes creating an optimal light environment for every activity during the working day. The representative part with references to the company and corporate culture and factors characterising the personality of the office user requires the usage of luminaires which give individual objects the opportunity to become apparent.



The LED sources with various luminous intensity which reflect the light from the built-in reflectors under different angles enable changing the width of the luminous intensity curve within one luminaire.

A recessed ceiling luminaire with a direct characteristic of the luminous flux distribution is equipped with a diffuser and emits a soft and non-glare light. The high colour rendering index CRI 80 and the UGR value under 19 makes it an ideal luminaire for the office spaces.

MEETING AND CONFERENCE ROOM

The meeting, training and conference rooms represent multimedia communication centres in every modern office building. Nowhere else is the need of a flexible, effective and at the same time pleasant lighting as important as right in these spaces.

The meeting, workshop and conference rooms are not only a place where the information is shared in great extent, the tasks are assigned and innovative projects are realised. They are also a mirror of the corporate culture and an exhibition of the most modern multimedia technologies. Their composing into the specific spaces and interactive usage almost every day defines the need of special solutions of the multifunctional illumination that enables interpreting various moods and creates adequate sceneries to them. This target can only be achieved by combining various types of luminaires and their appropriate layout.

The homogenous non-glare light of neutral white colour with the correlated colour temperature of 4,000 K. It supports the impression of the space's openness and makes conditions for concentrated work. During video-conferences it is a guarantee of safety and at the same time it enables the meeting participants to take notes. For the illuminance of the conference desk and the task area the determined values are maximally 500 lx, the lighting of the surrounding of the task area is to achieve the value of maximally 300 lx. For



The biologically effective illumination will make it easier to be maximally concentrated during the meetings and increase the employees' performance efficiency during the workshops. The desired atmosphere in the room can be achieved by integrating the function daylight simulation.

The conference, meeting and workshop rooms frequently fulfil a representative mission in the office building and are the place of meeting with the clients. By placing the accent lighting we can accomplish accentuating the objects referring to the company logo, values of company or the corporate culture. From the point of its utilisation it is a space which people do not permanently occupy therefore installing the presence detector can lead to savings of electricity. In the spaces with availability of the daylight from the point of view of savings it is suitable to consider the usage of the daylight sensor.

this purpose it is suitable to use suspended luminaires with a direct and indirect distribution of the luminous flux. A correct illumination of the board, presentation board or screen can be achieved by placing the lighting fixture at asymmetrical characteristics. The high-quality vertical lighting which makes orientation easier is very important for this type of the space. Increased demands are placed on the illuminance of the wall surfaces.

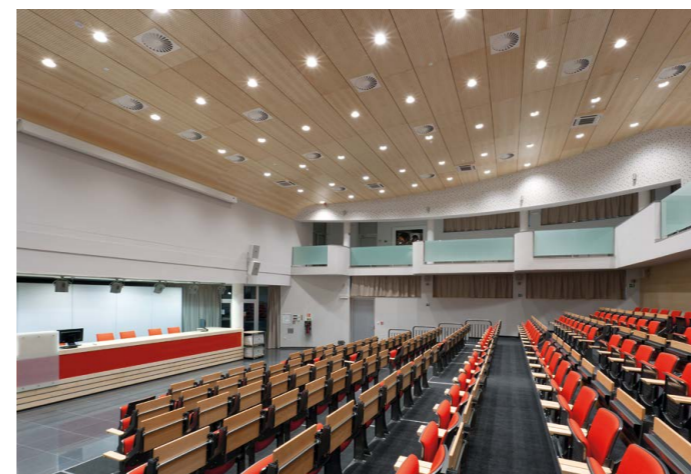
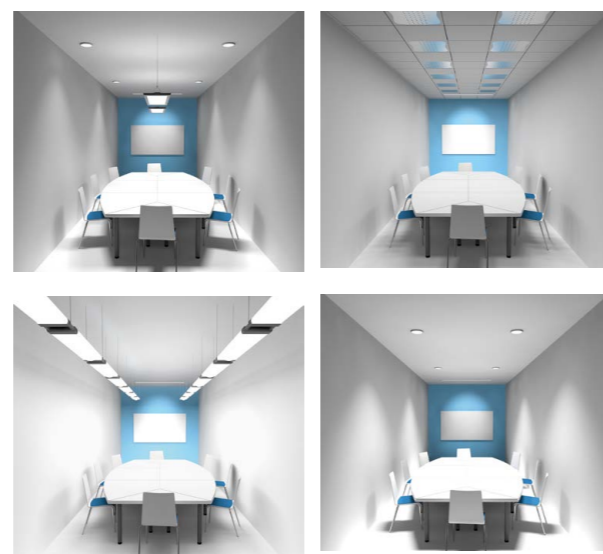



research & development

research & development

EXIT

RELAXATION ZONES

Nowadays the working people spend more than half of their lives at work. The modern office spaces are not cold, impersonal spaces any more but they respond to the natural needs of the employees and create zones determined for the informal communication and relax during the working day.

A café, restaurant or relaxation room with comfortable places for sitting is a common part of a modern workplace today. They provide a space for exchanging information in an informal environment and copy the natural biological needs of the human organism. The equipment and functional lighting of the relaxation zones contributes to the feeling of comfort, creates a space for having rest and increases the employees' motivation. In the zones determined for relaxation, equipped with comfortable furniture especially the indirect lighting will find its place. It will enable flexible changes in the room without any need to change the lighting solution. The cafés and restaurants in the office building place similar demands on the light solutions as any other premises of a similar type.

The basic premise when planning the illumination in these spaces is to use a correct light solution in every zone. It will create an impression of a homogeneous space. The display cases and spaces determined for presentation of the meals cannot do without the spotlights with an adequate CRI value which will show the co-

lour of the meal as truthfully as possible and are able to increase its visual attractiveness in this way. In the part determined for dining, the indirect light from the recessed luminaires is able to create a nice, but in spite of that a stimulating atmosphere and here we can organise an informal working meeting with

catering. Currently there is a common trend heading to the creation of a home atmosphere for all spaces defined as the relaxation zones. The furniture in warm colours (e.g. made of wood) becomes the dominant feature of the space as well as the pleasant illumination with the correlated colour tempera-

ture of 3000 K. For a lighting designer such a space provides inexhaustible creative opportunities. The task of the relaxation zones is to affect the people's emotions and therefore especially the ambient lighting will find its place in such spaces.

Modern employers respond to the natural needs of the employees and create zones for informal communication and relaxation during the whole day.

In the relaxation zones with a standard height of the ceiling it is possible to use the luminaires of the downlight type. The attractiveness of the space with high ceilings can be increased by installing designer suspended luminaires.

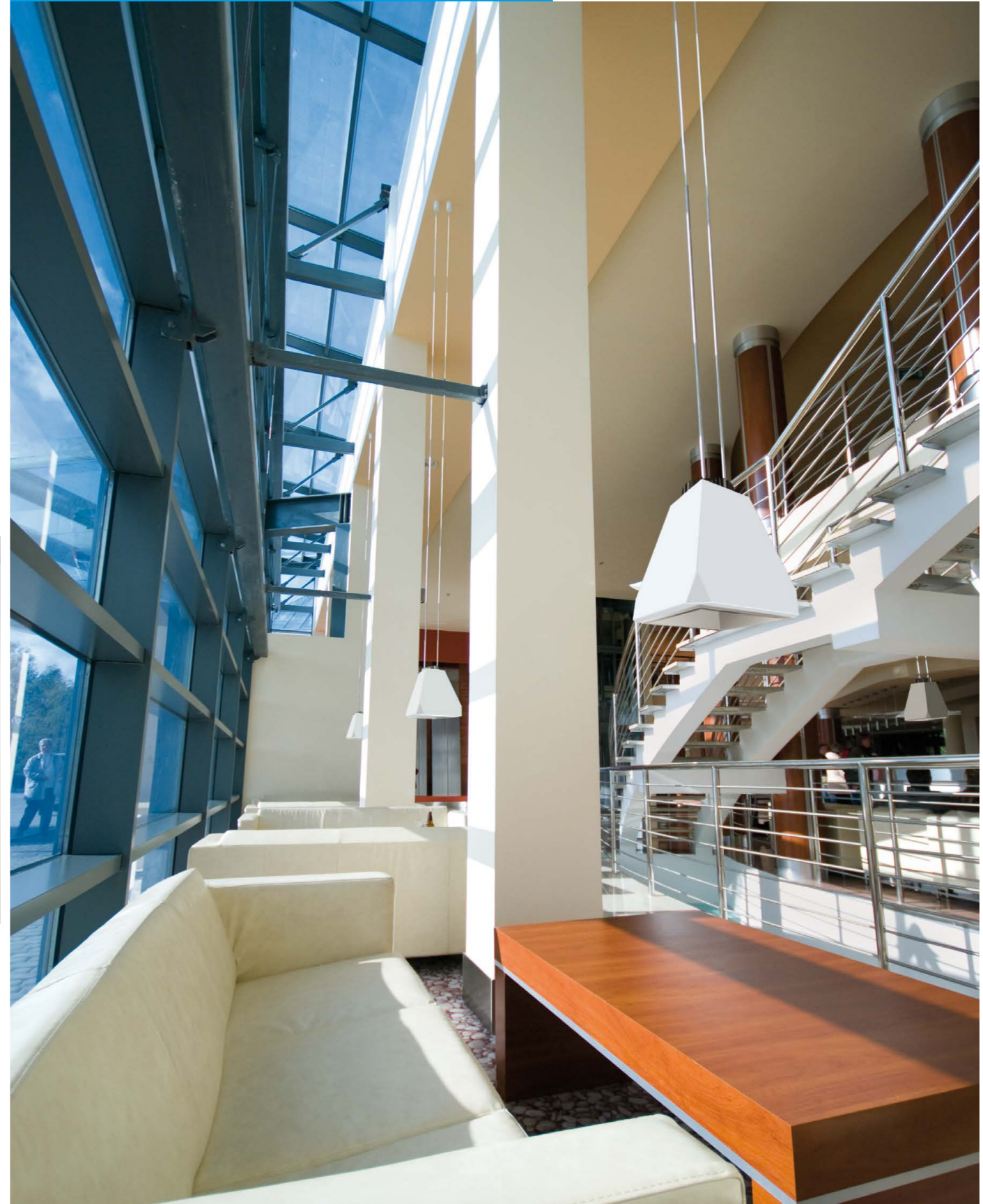
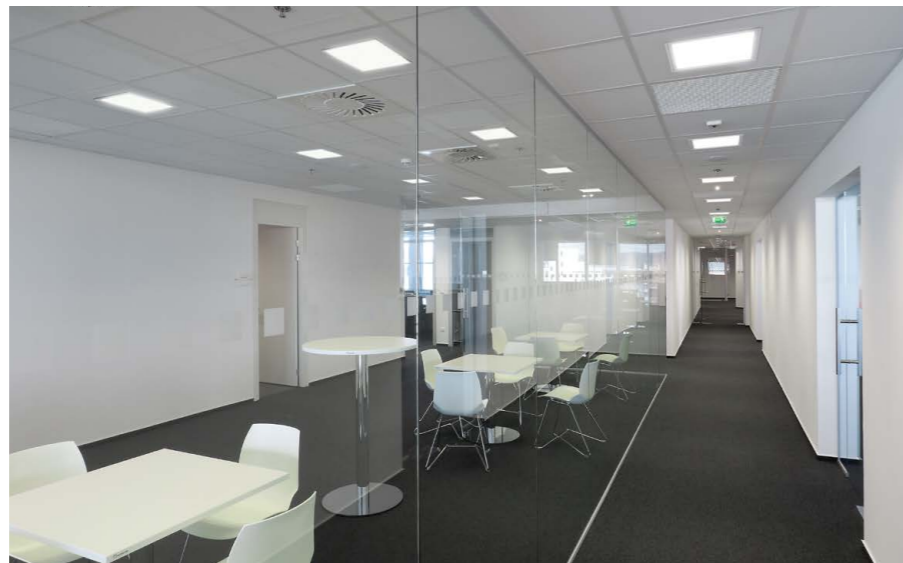



CORRIDORS AND COMMUNICATIONS

The corridors, staircases and elevators represent the communication paths connecting the key points inside the building in the framework of the office space. Their appropriate illumination brings easier orientation even in an unknown space, increases the feeling of comfort and safety.

The communication zones in the interior of the office buildings belong to the areas without any permanent occurrence of persons. In spite of this fact they also place certain demands on the lighting quality. Due to their long lifetime and wide colour spectrum the luminaires with the LED sources are optimal for this type of spaces. The lighting fixtures with a very wide radiation curve are used for the general lighting of the corridors. They are also able to effectively illuminate the wall edges and this brings an optical enlargement and brightening of the whole space. The ceiling surfaced luminaires with the direct or indirect luminous flux distribution, the ceiling surfaced luminaires with a wide radiation curve or suspended lighting fixtures with direct or indirect luminous flux distribution belong to this category. The illumination of the vertical surfaces is the most important

from the point of view of the correct lighting of the corridor and the communication zones. The illumination of the ceiling is also important, especially due to the feeling of orientation. The luminaires with a wide curve of the luminous intensity or suspended lighting fixtures with the direct or indirect luminous flux distribution that sufficiently illuminate all the corridor surfaces are suitable for this purpose. The long corridors can add interest by works of art or paintings referring to the corporate culture. The accent luminaires with a narrow beam angle are able to improve the attractiveness of this space.

By placing a line of luminaires to the upper ceiling corners of the corridor, the so called cove lighting, we can achieve its optical enlargement. This type of illumination belongs to the group of the ambient lighting and it is often completed by the RGB function for mixing colours. The technology RGBW is used for reaching better pastel colours.

The additional orientation luminaires recessed in the floor or the corridor wall give direction to the strategic points in the office space and especially fulfil the orientation and safety function. They fulfil the same functions on the staircases which

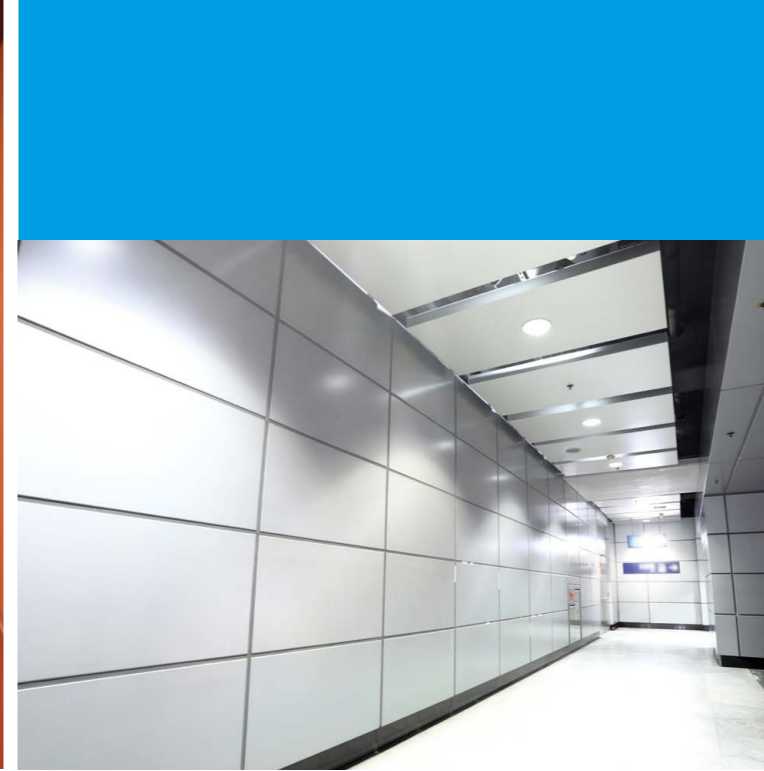

represent not only another communication but currently also a representative zone in the office space. When selecting the correct type of illumination we especially emphasise the minimisation of shadows and visibility of individual steps. Recessing the LED luminaires to each third step we achieve improvement of safety and

comfort for movement on the staircase. Due to the fact that the corridors and staircases fulfil the task of escape routes, during the designing process it is inevitable to schedule for installing the safety and emergency luminaires in compliance with the legal standards (see the chapter Safety and Emergency Lighting).

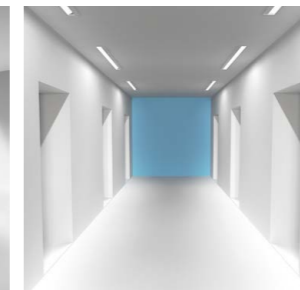
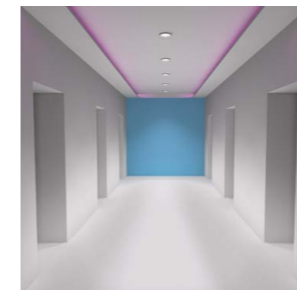
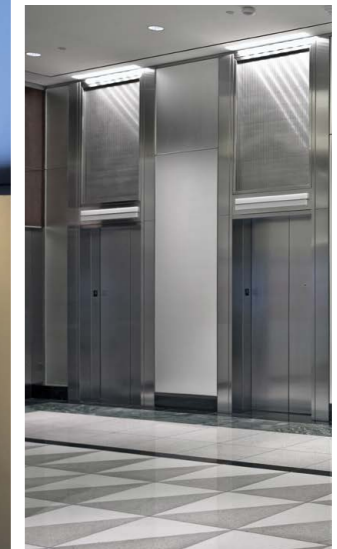
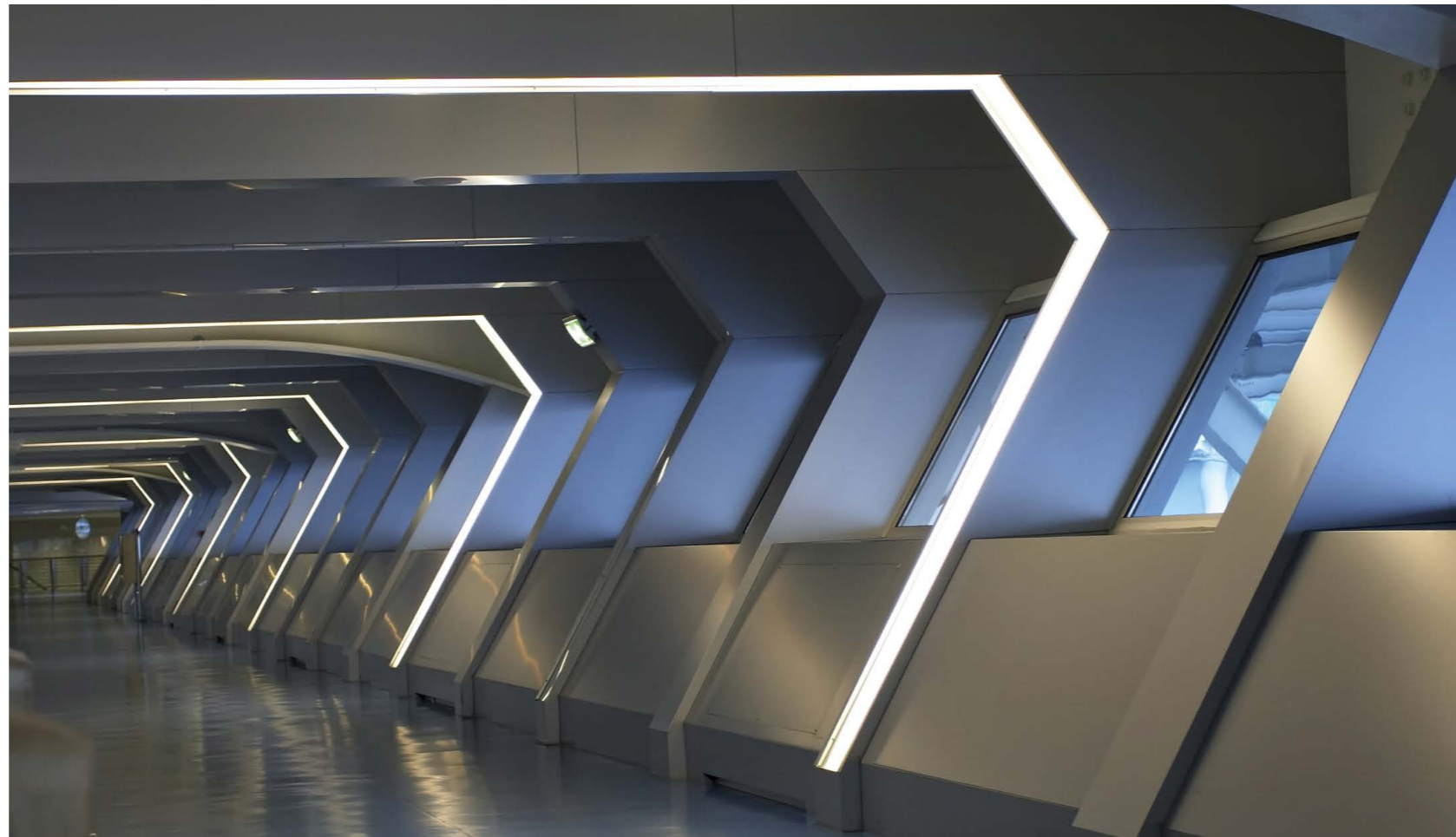

Different lighting designs can highlight doorways using negative or positive contrast. Cove lighting creates atmosphere, whereas highly illuminated walls give the sense of the corridor being more open and airy.

SAFETY AND EMERGENCY LIGHTING

In the spaces with an increased concentration of persons, rooms without any access of the daylight and in the communication zones determined for escape paths the safety and emergency lighting helps to solve collision situations and reduces the risk of injury.

Regardless to the fact if it is a power cut, danger of fire or another crisis situation, the task of the safety and emergency lighting is to ensure the persons basic visibility and orientation during leaving the space or to make their access to the fire extinguishers easier. Correctly planned and carefully maintained emergency lighting can prevent an outbreak of panic, injuries and even save lives. When selecting the type of the emergency lighting the requirement on its long-term lifetime and the ability to fulfil its tasks at good visibility also during the power cut plays the most important role.

The battery pack LED luminaires represent the optimal solution – the producers guarantee here the minimal lifetime of 50,000 hours. In this way the maintenance costs are reduced and compared to other light sources the user can save up to 70 % of the power consumption.

The effectiveness of the LED emergency lighting can be increased by installing the additional optics and reflectors which will reduce the number of the LED luminaires when the legal standard is fulfilled.

The requirement on the safety and emergency lighting is adapted by the European standard EN 1838. The EN 1838 standard specifies the minimum horizontal lighting needed to be 1 lx along the central axis of escape path that has to be at least 2 m wide.

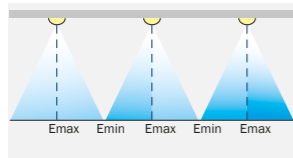
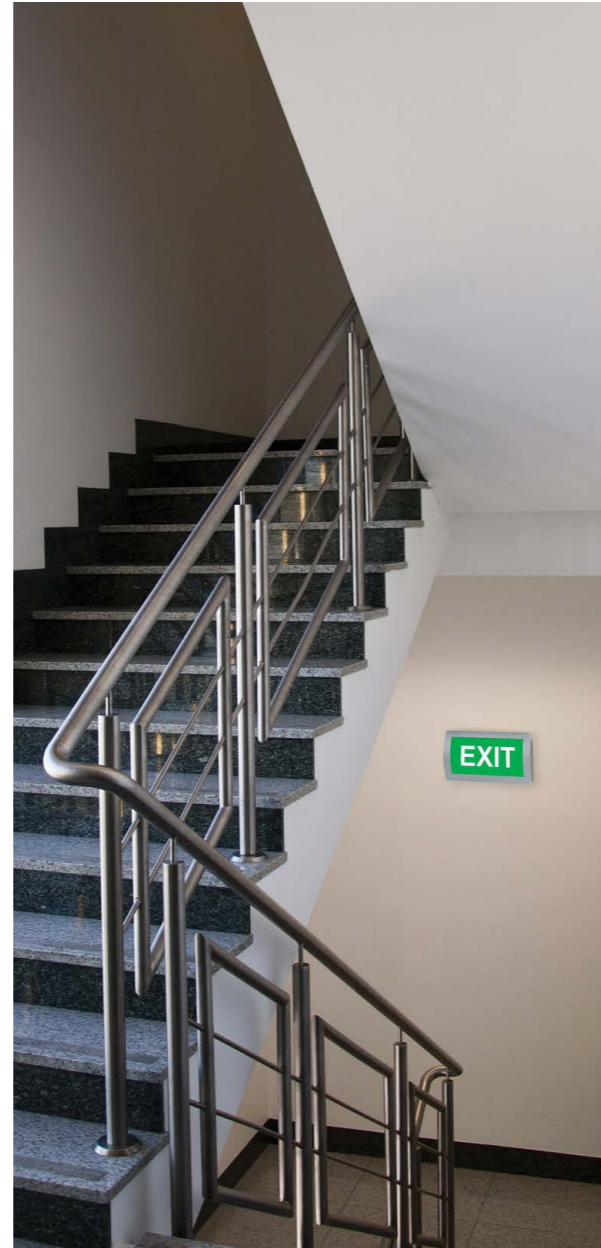

REQUIREMENTS ON EMERGENCY LIGHTING
 Illuminance $E_{min} = 1 \text{ lx}$
 Uniformity E_{max} :
 $E_{min} \leq 40: 1 \text{ lx}$
 Colour Rendering Index $CRI \geq 40$
 Operating time 1 h
 Activation of lighting 50 %, or for required illuminance within 5 seconds, 100 % within 60 seconds

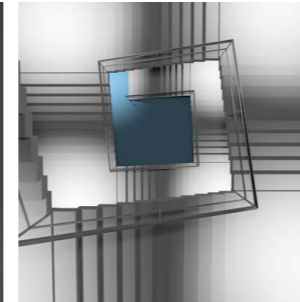



FACADE

The task of the office of building illumination is not only to make it visible during night hours. The light as the fourth architectural dimension is able to accent the construction character, to emphasise interesting details and at the same time to communicate the message of the company and corporate culture. The head building is a flagship of every successful company and is determined not only for carrying up the operative activities but also for representation.

The correct facade illumination is able to breathe style and elegance to the modern glass-walled buildings; it helps to accent the not interchangeable character of the historical ones. The play of light and shadow is able to conjure dramatic sceneries in dependence on the type of lighting and installation of luminaires and to breathe the office spaces life even after ending the working hours.

The illumination of large facade surfaces can be achieved by installing luminaires with a wide luminous intensity curve placed e.g. on the columns in front of the building. When we place an accent luminaire directly on the facade wall, it can emphasise interesting architectural as well as artistic elements, e.g. the sculptures, to emphasise the stuccowork of a historical building or to illuminate solved cornice in an interesting way.

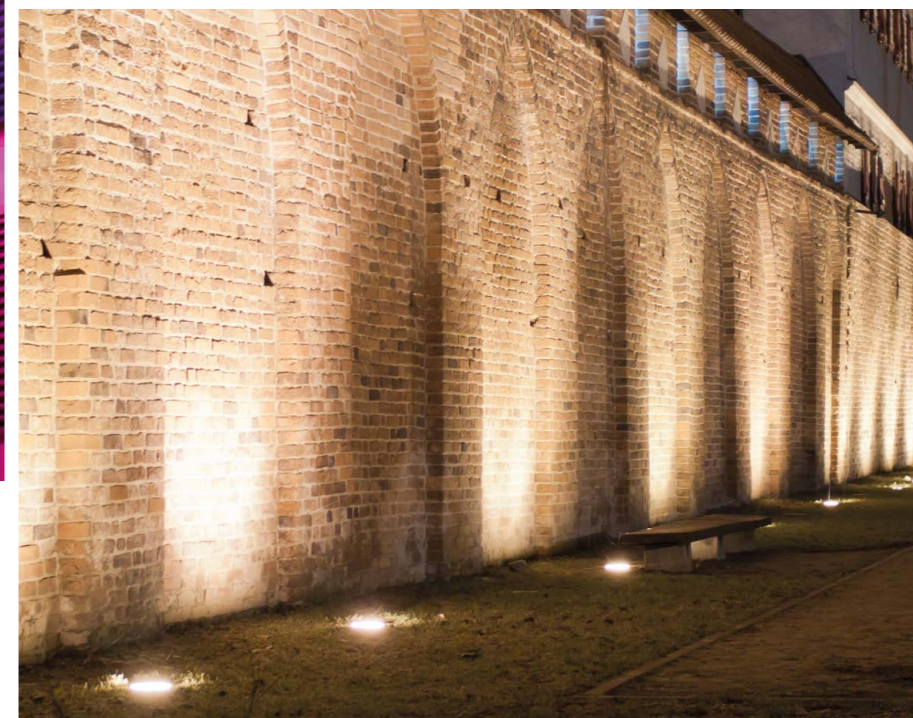
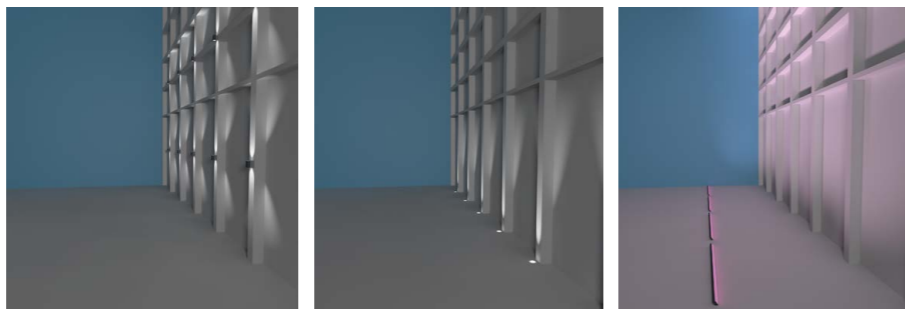
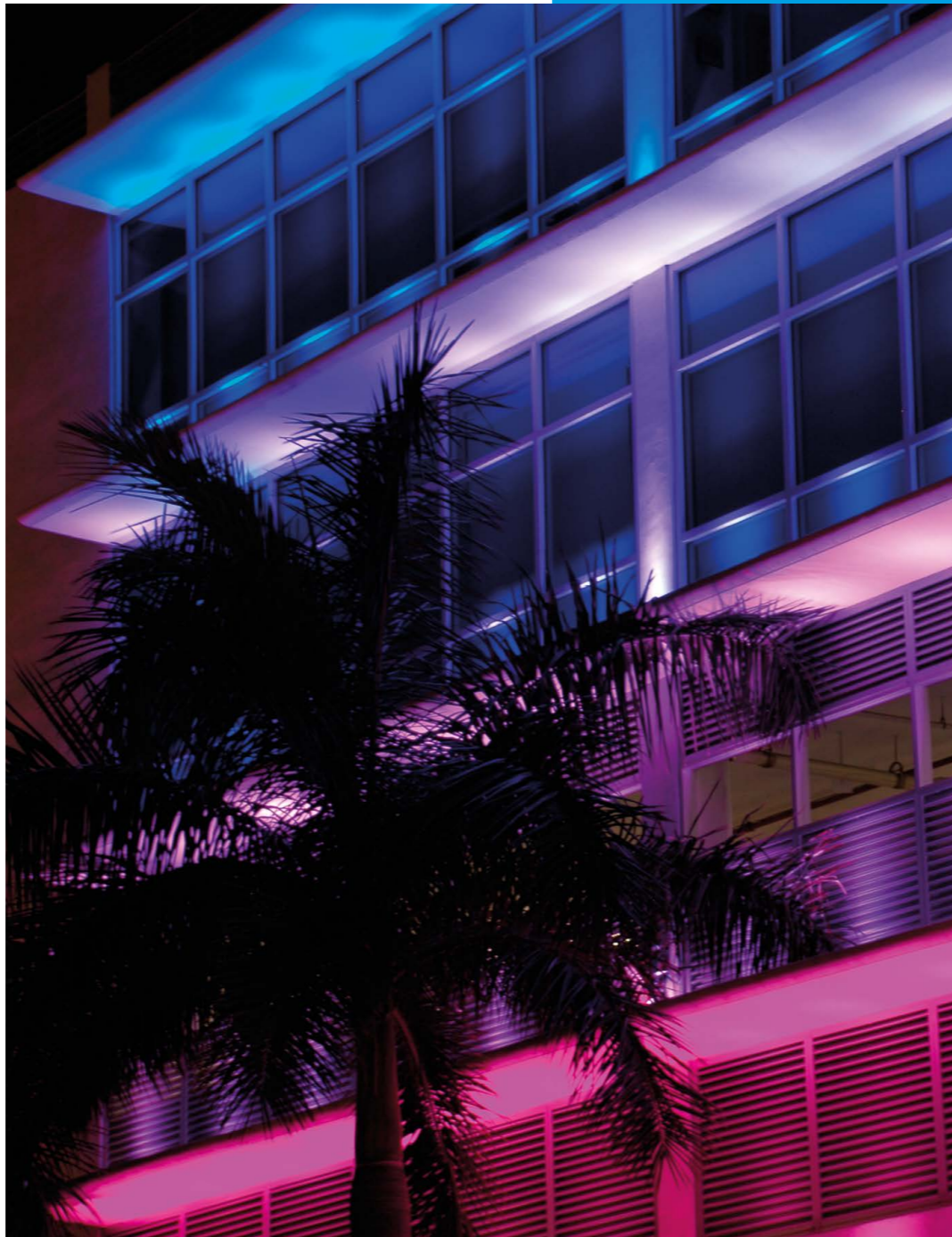

The modern architecture with clean lines is flattered by a white neutral light and vice versa, the historical buildings become apparent after dark in the light of warmer colours.

The luminaires recessed to the ground with an asymmetric radiation curve placed in an optimal distance from the facade accent the vertical contours of the walls, their lighting by spotlights from the bottom emphasises the architectural details of the building (balconies, cornices, sculptures, etc.). The used LED luminaires can be enriched by the RGB function of mixing the colours and to strengthen the emotional effect of the illumination.

When planning the light solution of the facade the selection of the light colour is one of the decisive factors. The modern architecture with clean lines is flattered by a white neutral light and vice versa, the historical buildings become apparent after dark in the light of warmer colours. The dynamic illumination is able to increase the at-

tractiveness of the light solution by gradual switching on and off of the selected scenes or the company logo.

From the point of view of selecting a light source also in the case of the facade illumination, it is valid that effectiveness, functionality and economy of the LED luminaires highly exceed the parameters of the standard metal-halide lamps. The LED RGB modules are able to interpret up to 16.7 million colour tones, they work more reliably also at low external temperatures and thanks to their long lifetime they reduce the demands on the service and maintenance. The exterior illumination of the office building requires sophisticated light solution also because of the orientation and safety. Beside representation its task is to enhance the fast orientation in the space (e.g. to lead to the main gate or entrance to the parking lot) and to improve the safety of the moving persons during the night hours.

However, during solving the facade illumination, we should not forget about the lighting of the adjacent green areas. The coniferous and broad-leaved trees become apparent in the light of the sodium discharge lamps, while the dark-green trees in the light of the metal-halide light sources. By their suitable placement we can achieve an attractive multi-colour effect.



EXTERIOR ILLUMINATION AND PARKING AREAS

Besides the aesthetic task, the exterior lighting especially fulfils the security function. It makes the orientation in the external spaces easier, it refers to the entrances and the entry ways to the building, it increases the feeling of safety and comfort.

The increased demand on the illumination of the external spaces is especially where the pedestrians, bikers and car drivers meet. The correctly illuminated vertical as well as horizontal areas minimise the risk of collision and provide enough information about the orientation in the space. The access roads and external parking lots are made visible by the pole luminaires; decent in the ground recessed lighting fixtures separate the parking areas from the traffic lanes and the pedestrian zones. For all types of luminaires for external usage there are strict criteria as to the resistance against humidity, the temperature fluctuations and pollution. Also the underground parking lot places special demands on the intensity and type of illumination, beginning with the luminaire marking the entrance and way out, through the guidance lighting up to general lighting of the functional area.

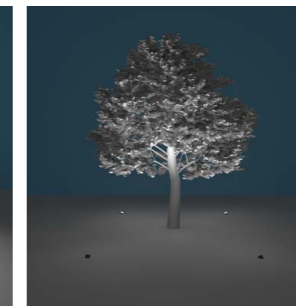
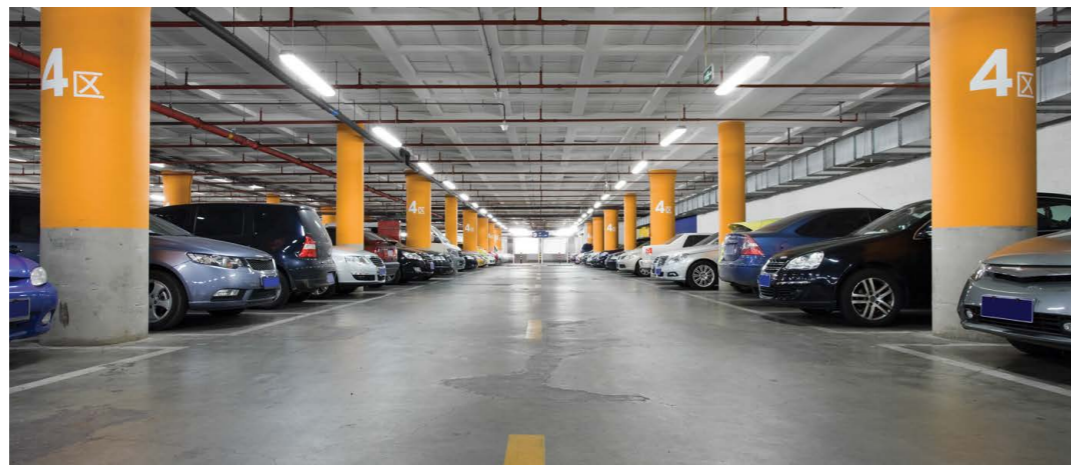

One of the most important tasks of the lighting system designers when they solve the illumination of an underground parking lot is the entrance and exit zone from the parking area in the framework of which the light scenery is distinctively changed. Such an environment places extraordinary demands on the adaptation phase of the human eye during transition from various light environments. It is inevitable to reduce this phase to minimum. The optimal solution includes a higher density of the luminaires installed in these zones (similarly as in the tunnels) which means a softer transition.

The task of the general lighting in the underground parking lot is not only to ensure the basic visibility but to provide the person in the parking area a feeling of comfort and security. For the road users in the parking lot environment to be able to assess and solve the situation sufficiently quickly, it is inevitable to choose the luminaires with the lighting intensity of minimally 75 lx. In general it is recommended to use the luminaires in anti-vandal version

and a long lifetime placed on both sides of the traffic lanes. A sufficient illumination especially in the areas with irregular occurrence of people is inevitable also from the security point of view. It enables the persons to recognise faces and to respond in time to the first signs of aggression.

When designing the light solution it is to also take into account the lifetime of the light sources. From the point of view of the lifetime and demandingness on the maintenance the LED luminaires are especially suitable. As they are areas without any access of daylight and at the same time without permanent occurrence of persons, it is suitable from the point of view of energy saving to consider the installation of the constant illuminance sensor and presence detector that scans the movement of the vehicles in the garage, manages the illumination in the zones where it is necessary and creates the guidance lines in the area of the underground parking lot.

SELECTION OF THE RIGHT SOURCE

The individual areas in the hotel and gastro spaces have different demand on the illumination. When designing a lighting system the task of the lighting designer is to choose the light sources with the most suitable parameters where besides the procurement price the categories of effectiveness, lifespan and safety are also included.



Lamp type	power rating from-to [W]	luminous flux from-to [lm]	efficacy [lm/W]	light colour	colour rendering index (CRI) from-to	lifespan from-to	lampholder
Incandescent	30-100	300-1000	10-12	ww	> 90	1000	E27, E14
Tungsten halogen	5-116	60-2135	12-22	ww	> 90	2000	E27, E14, G9, GU10, GZ10
Tube-shaped fluorescent FD (T8) Ø 26 mm	18-70	860-6200	61-93	ww/nw/dw	80-96	16,000-80,000	G13
Tube-shaped fluorescent FDH (T5) Ø 16 mm	14-80	1100-7000	67-106	ww/nw/dw	80-93	24,000-45,000	G5
Compact fluorescent lamp	5-80	250-6500	46-95	ww/nw/dw	80-90	5000-32,000	2G11, 2G7, 2G8-1
High-pressure metal halide lamp MT/ME (HIT/HIE)	35-2000	3200-240,000	67-120	ww/nw/dw	65-96	6000-15,000	E 27, E 40, PG12-2
High-pressure sodium lamp ST/STH (HST)	35-1000	3500-150,000	74-150	ww	20-25	12,000-32,000	E 27, E 40, PG12-1
Double ended metal-halide lamp MD/MN (HID)	70-2000	5500-230,000	73-117	ww/nw/dw	65-95	4500-15,000	RX7s, K12s
Double ended high-pressure sodium lamp SD (HSD)	70-150	6800-15,000	97-100	ww	20-25	12,000-32,000	RX7s
LED retrofit	3-7	90-800	37-70	ww/nw/dw	80-90	5000-20,000	GU10, E27
LED module	1-140	100-17,200	90-200	ww/nw/dw	70-98	50,000-100,000	-

ww = warm white correlated colour temperature (CCT) below 3300 K
 nw = neutral white correlated colour temperature (CCT) 3300 K to 5300 K
 dw = daylight white correlated colour temperature (CCT) over 5300 K



LED FOR OFFICE

When in 1962 the American professor Nick Holonyak created the prototype of the first “light emitting diode” – LED, his invention remained almost unnoticed. The only one who anticipated its revolutionary future on the pages of the magazine Reader’s Digest was the inventor himself. It lasted almost forty years until the industry revealed all the exceptional properties of the LED and learned how to utilise them. In the lighting industry the LED sources currently represent an area that is developing in the most dynamic way.

In what respect are the LED light sources so exceptional and exceed the properties and parameters of the conventional sources? Why do the architects, developers and users of industrial buildings concentrate more and more frequently on the LED sources when designing the lighting systems? It would be possible to answer in a very simple way: The LED sources are highly effective, they have a long lifespan and an excellent colour rendering, they are cost-effective and environment-friendly. But let us have a look at the individual categories more thoroughly and we will explain why the LED sources represent also for

your industrial spaces the best solution.

The LEDs are light sources based on the semi-conductor basis. A very small amount of energy is necessary for emitting the light. The diodes emitting light consist of two types of semi-conductors – the N-type with surplus of electrons and the P-type which has lack of electrons (the so called holes). After connecting the power the excessive electrodes and holes begin to migrate to the PN junction. When they meet the recombination develops and the diode starts emitting photons. By its size that is not larger than a dot made by a pencil the LED ranks among the smallest light sources. The package which is at

the same time a lens serves as protection. It enables distributing the luminous flux directly under the angle 15° to 180°. While a common light bulb is able to change into visible light only 5 % of the electric power, the LED with its ability to change up to 40 % of the total energy reaches incomparably better parameters in this category. The efficiency of the light source or its efficacy says with what efficiency the

electric energy is changed into the light, i.e. how much of luminous flux it produces from the electric input power (W) delivered to the light source. The unit is lumen per watt (lm/W). While the first white LEDs in 1996 had an efficacy of 0.1 lm/W, today there are commercially available LED chips with an efficacy of 200 lm/W for cool white CCT LED and in the labs there has been achieved an efficacy of up to 303 lm/W.

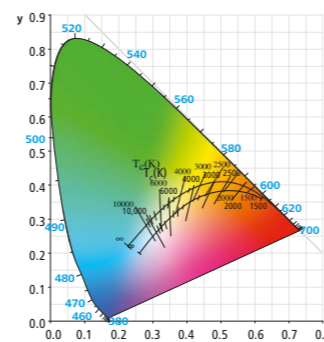

If the LED sources after binning are on the Planck curve, they emit “pure white”, i.e. pure white light.

The LED luminaires used in the industrial and production spaces have to fulfil high ergonomic and economic requirements. In the industrial areas they are required to deliver high-quality, glareless lighting for the optimal visual comfort also for the Visual Display Units (VDU) and at the same time they have to fulfil the requirements of the European standards. The LED diodes are primarily the source of the white colour radiation. The white LED light can be acquired by various methods; however, the principle of luminescence is most frequently used for its production. In this method a thin phosphorus layer is applied to the blue LED which, after the switching on of the source, changes part of the blue light which passes it into the white one. This technology of the LED production enables achieving the emission of the white light with various correlated colour temperature from 2700 K to 10,000 K.

Another method making it possible to acquire the white LED light consists of mixing the coloured light of various wavelengths. Through additive mixing the red, green and blue colours (RGB) the white light can arise. The advantage of this method is that besides the white light by targeted mixing we can also acquire coloured light. The disadvantage when acquiring the white light by the RGB technology consists in its demandingness. It requires a lot of know-how because the management of the coloured LED with various values of luminance is demanding and the white light produced often achieves lower values of the colour rendering index CRI 70 - 98. If we consider changes of the correlated colour temperature of the white light when solving the illumination in the industrial spaces, it is suitable to combine the coloured chips with white LEDs. In this way optimal CRI values are obtained.

COLOURS STRAIGHT FROM THE SEMICONDUCTOR

Colours straight from the semiconductor

LEDs do not require colour filters: their light comes in different colours produced directly by different semiconductor materials. Secondary colours are also possible. The major semiconductors are:

Semiconductor material	Abbreviation	Colour(s)
Indium gallium nitride	(InGaN)	Blue, Violet
Gallium(III) nitride	(GaN)	Blue, Violet, Ultraviolet
Aluminium gallium indium phosphide	(AlGaInP)	Red, Orange, Yellow, Green
Gallium(III) phosphide	(GaP)	Red, Orange, Yellow, Green
Aluminium gallium phosphide	(AlGaP)	Green
Indium gallium nitride/Gallium(III) nitride	(InGaN)/(GaN)	Green

The lifespan of the LED sources moves in the values of up to 100,000 hours which represents 22 years for 12-hour-operation daily, 365 days a year.

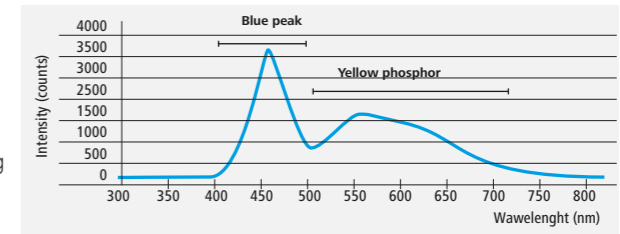

White light can be produced by combining blue and yellow light only. Sir Isaac Newton discovered this effect when performing colour-matching experiments in early 1700 s.

SPECTRA OF WHITE AND COLOURED LEDs

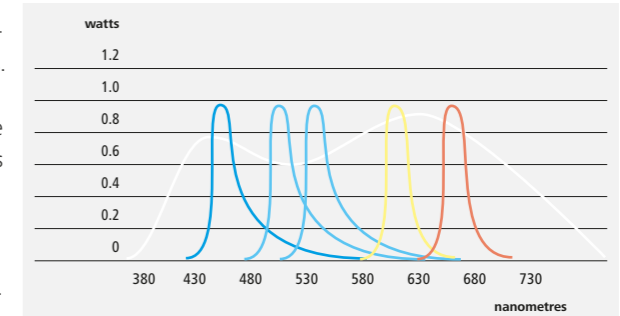

LEDs do not require colour filters. The colour tone of the light is determined by the semiconductor material used and the dominant wavelength.

From the point of view of the lifespan the LED light sources achieve above-average parameters. Their lifespan moves in the values of up to 100,000 hours which represents 22 years for 12-hour-operation daily, 365 days a year. The drop of the light source performance to 70 %,

in some cases to 5 % is introduced as the LED lifespan end. It means that the LED failure rate is substantially lower compared to the conventional sources. However, appropriate cooling of the light source is a necessary condition for maintaining the lifespan parameters.

DEFINITION OF LIFESPAN

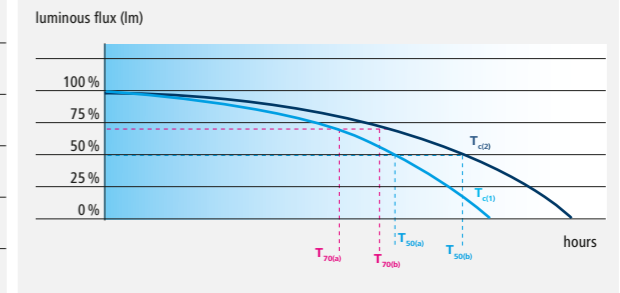

LEDs do not fail but the intensity of the light they produce diminishes over time. The lifespan (L) of an LED thus needs to be defined for different applications. For emergency lighting, for example, rating up to L80 are more required, this means that the LED reaches the end of its service life when the luminous flux falls to 80 percent of the original flux measured. For general lighting, values of L50 or L70 are defined. The lifespan of an LED depends to a large extent on ambient and operating temperature. Where an LED is operated at a high temperature (Tc1) or with poor thermal management, its life is shortened.

In spite of higher purchase costs the LED sources represent in a longer-term horizon the most effective and economical light solution. The experts estimate that if we replaced all existing light sources for the LED ones today, the energy savings worldwide could reach the amount of 30 %. If we realise that the artificial lighting consumes up to one fifth of the energy produced, this amount is not negligible at all. When we take into account a smaller area illuminated by obsolete conventional sources, we would be able to save up to 75 % of lighting system input power by the controlled LED illumination. All light sources also produce the IR radiation during the change of the electric power into the light which the human organism perceives as heat. However, the LED light sources produce it in a negligible amount compared to the conventional sources and thus they do not increase the inadequate costs for the air-conditioning power consumption. The lifespan and failure rate of the LED sources reduces the lighting system maintenance costs as it does not require any regular interventions of service staff and purchasing new light sources.

The LED source saving potential can be maximised by installing the intelligent lighting management which enables adjusting the radiation intensity of every luminaire in the lighting system automatically in dependence on the availability or intensity of the daylight.

The environment-friendly approach is a topic also for the producer of the light sources today. The reality is that the majority of the conventional light sources cannot be produced without using the toxic heavy metals – lead and mercury. The users of the premises equipped with this type of light sources have an additional burden when they replace them as they are compulsory to remove the used or damaged sources in compliance with the law about disposal of the toxic waste and on the other hand they are exposed to the risk of breathing the toxic vapours when the light source is damaged. In this respect the LED sources represent an incomparably lower risk. Though they contain a small amount of heavy metals, they are in solid state and so there is no danger of breathing in the toxic vapours when the LED source is damaged.

Thermal management

Similarly as in the case of other light sources, the temperature significantly affects the performance of the LED light source. Without any adequate thermal management overheating of the LED source can develop and it reduces its lifespan and the risk of its damage is also

increased. Implementing a suitable cooling system we achieve maintaining the declared lifespan of the LED light source and its high efficacy. From this point of view the thermal management represents the most critical factor for the luminaires with the LED source.

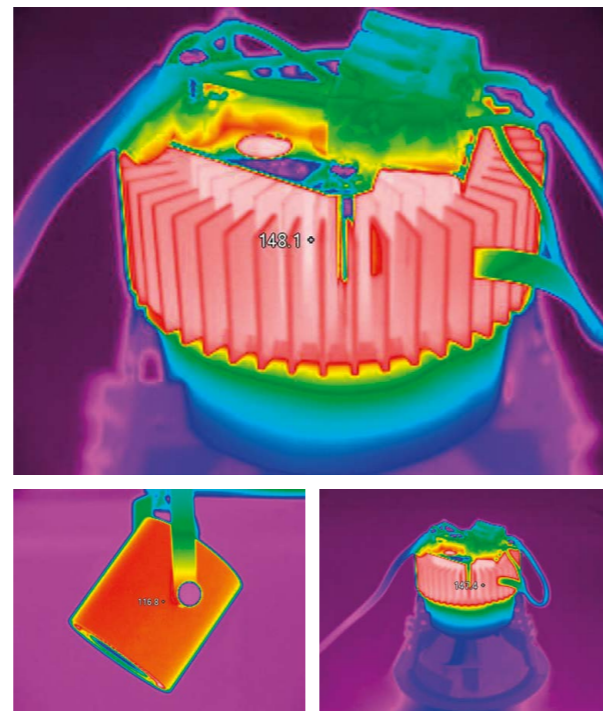

Thermal output of DW Prettus and Avior

Binning

During the industrial production of LEDs deviations of the key parameters arise in the individual batches. In the framework of one batch the parameters are generally the same, but when we compare two various batches, the LEDs differentiate e.g. in colour or the luminous flux. To ensure the constant quality of light with the same level of luminance and colour of the light, it is inevitable to sort out every batch according to the value of individual parameters. This sorting is called binning. The main criteria taken into account when binning are as follows: the luminous flux measured in lumens (lm), the correlated

colour temperature measured in Kelvins (K), the forward voltage measured in volts (V). The LED sources are nowadays classified according to the binning standard ANSI. This standard defines the colour shades of LED by the MacAdam ellipses which depicts the colour deviation on the axis X and Y. The MacAdam ellipses shows how the colour of the individual LED modules can differ. The binning standard ANSI recommends for the resulting colours to be inside of the ellipse on the curve with four threshold values. The binning groups of the LED sources which show minimal differences of the values measured will produce the light of the same colour.

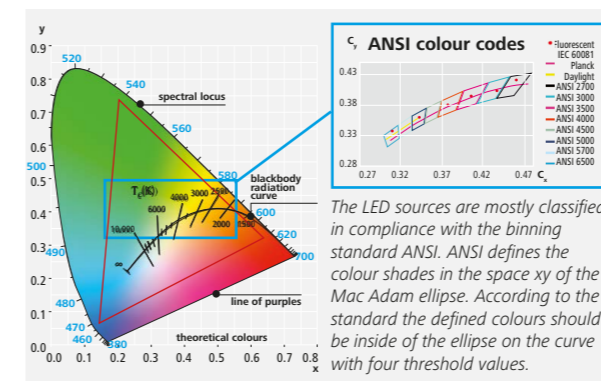

PWM control

The Pulse Width Modulation (PWM) represents the most effective method how to check the intensity of the LED light source. The PWM principle is based on periodical switching on and off of the constant current directed to the LED. The resulting intensity of the LED light source is characterised by the ratio between the state of switching on and off. The frequency of switching on and off is adjusted for the human eye to perceive the emitted light as a continuous luminous flux. Its intensity depends on the adjustment of the PWM cycle (0 % to 100 %). The advantage of the impulse width modulation is the

maintaining of the constant correlated colour temperature in the whole range of dimming.

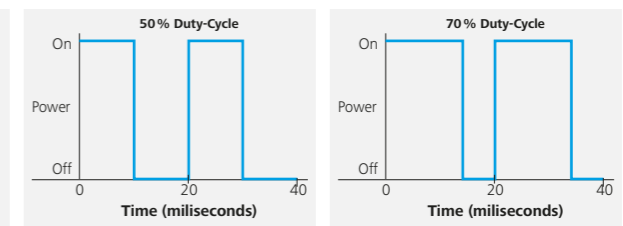

Compared with the conventional light sources the LED light sources reach the full luminance immediately. The immediate start of the LED source is a benefit from the point of view of safety and comfort. At the same time compared to the conventional sources, frequent switching on and off does not make any damage to the LED source and does not reduce its lifespan as well.



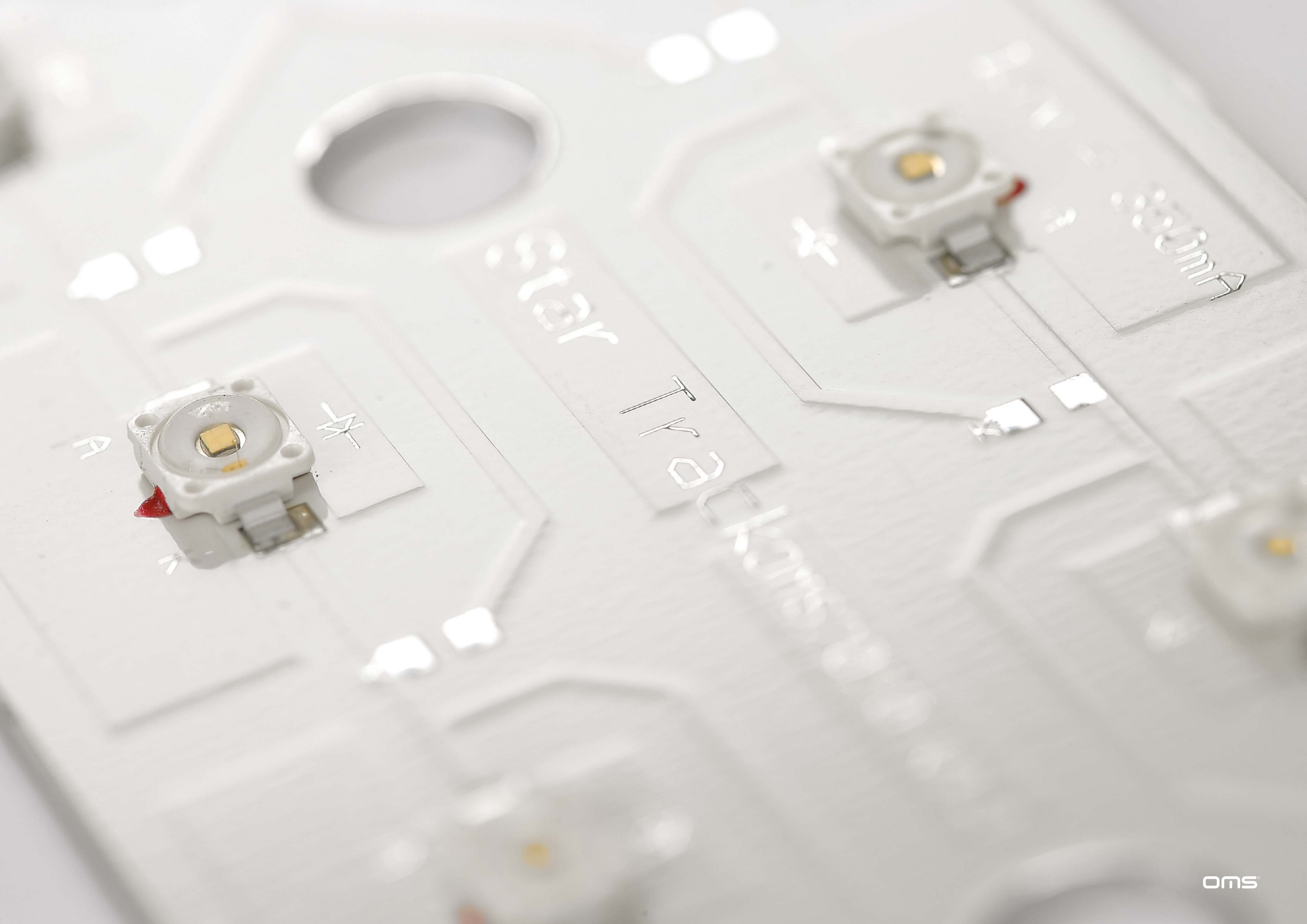

BASIC TERMS

LUMINOUS FLUX Φ

The luminous flux is a physical quantity which states how much light in total a light source emits to all directions. It is the radiant power of the light source assessed from the point of view of the human eye sensitivity. The luminous flux expresses the ability of the radiant flux to cause a visual perception. The unit of the luminous flux is lumen (lm).



EFFICACY η

The luminous efficacy states with what efficiency the electric power is changed into the light, i.e. what proportion of the luminous flux is produced from the input power (W) delivered to the light source. The unit is lumen per watt (lm/W).

LUMINOUS EFFICACY OF THE SOURCE

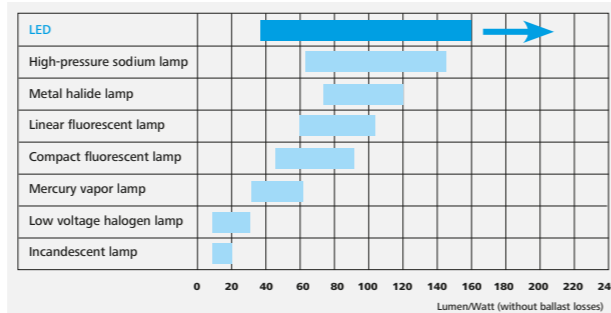

LUMINANCE L

The luminance is the gloss of the shining or illuminated surface as the human eye perceives it. The unit is candela per square metre (cd/m²). This quantity gives the level of the luminous intensity over the specified surface area. The luminance of the illuminated surface depends in a great extent on its reflectance.

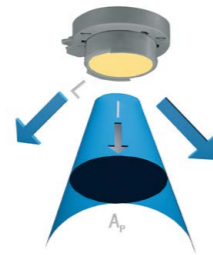

LUMINOUS INTENSITY I

The luminous intensity is a physical quantity which states what volume of the luminous flux the light source (or luminaire) emits to the elementary solid angle in the direction evaluated. The unit of the luminous intensity is candela (cd).

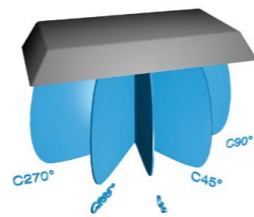
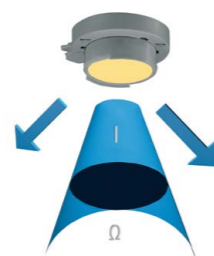

intensity distribution curve

ILLUMINANCE E

Illuminance is a vector quantity which states what amount of the luminous flux falls to the illuminated surface. The unit of the illuminance is lux (lx).

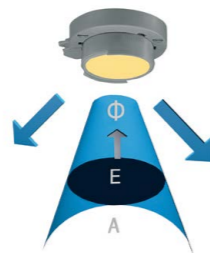

GLARE

If too great luminance occurs in the field of vision of the eye, its differences or the spatial or time contrasts which exceed the vision adaptability, the glare arises. During the glare the activity of the visual system is deteriorated.

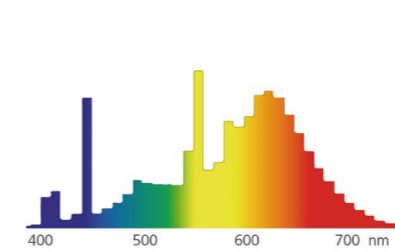

2,700 K

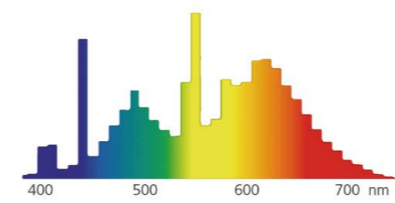

4,200 K

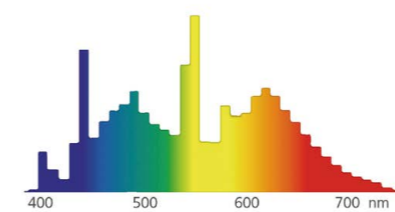

6,500 K



CORRELATED COLOUR TEMPERATURE (CCT)

The correlated colour temperature of the light source determines the atmosphere in the room. It is defined by the correlated colour temperature of the light source expressed in kelvins (K). Low temperatures create a warm light, the high ones the cooler ones. The most used light colours are the warm white (below 3300 K), the neutral white (3300 to 5300 K) and the day white colour (over 5300 K). The warm white colour is predominantly used for emphasising the red and yellow colour. The blue and green colours become apparent at higher temperatures.

CRI 70

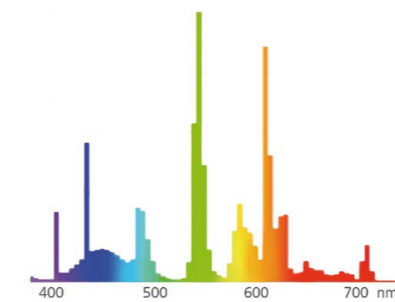

COLOUR RENDERING INDEX (CRI)

The properties of light source colour rendering are given in the levels of the general index of colour rendering – Ra. The CRI gives the rate of the congruence of the object surface's real colour illuminated by the considered light source under stated conditions of comparison. The smaller this difference is, the better the property of the colour rendering of the given source is. The light source with Ra = 100 renders all colours completely equally as a standard light source. The lower the index Ra is, the worse the colour rendering is.

CRI 95

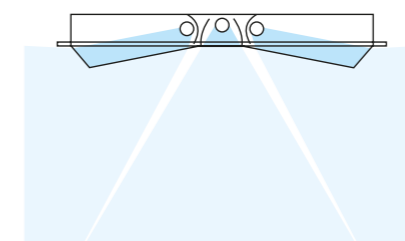
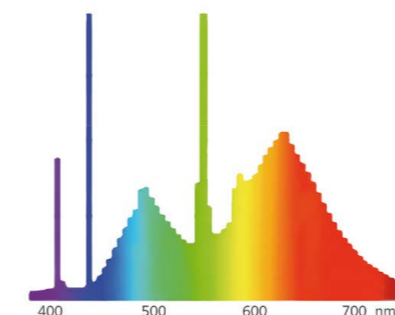

The Light Output Ratio is the ratio of the luminous flux coming out of the luminaire and the sum of the luminous fluxes from all light sources.

LIGHT OUTPUT RATIO (LOR)

